



# MATHESON

ask. . .The Gas Professionals™

## 5M SERIES MINI MANIFOLDS

INSTALLATION  
AND  
OPERATION  
INSTRUCTIONS

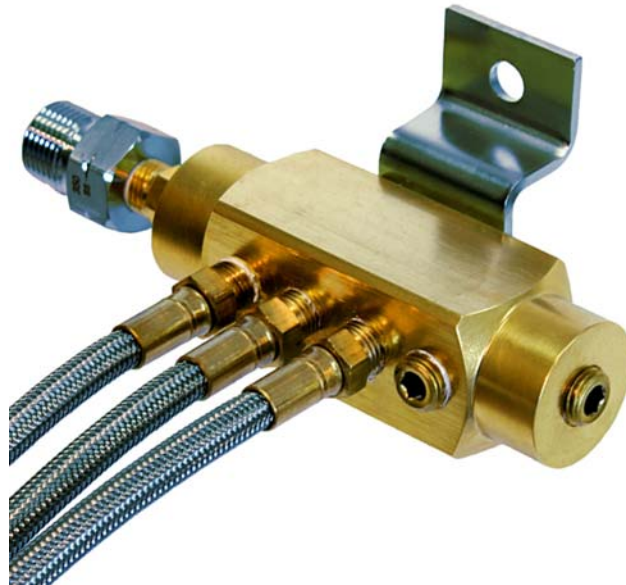

166 Keystone Drive  
Montgomeryville, PA 18936  
Telephone: 215-641-2700  
Fax: 215-641-2714

## **TABLE OF CONTENTS**

Limited Warranty.....	3
User Responsibility.....	3-4
General Service.....	4
Safety Precautions.....	4-5
Product Overview.....	6
Installation.....	7
Gas Cylinder Installation.....	8
Start-Up and Operation.....	9
Cylinder Replacement and Manifold Shutdown.....	10
Mini Manifold Drawing.....	11
Common Options Drawing.....	12
How to Order.....	13

---

## LIMITED WARRANTY

---

This equipment is sold by Matheson Tri-Gas (MTG) under the warranties set forth in the following paragraphs. Such warranties are extended only with respect to the purchase of this equipment directly from Matheson or Matheson's Authorized Agent as new merchandise and are extended to the first Buyer thereof other for than the purpose of resale.

For a period of one year from date of original delivery (ninety days in corrosive service) to Buyer or to Buyer's order, this equipment, is warranted to be free from functional defects in materials and workmanship and to conform to the description of this equipment contained in this manual and any accompanying labels and/or inserts, provided that this equipment is properly operated under the conditions of normal use and that regular and periodic maintenance and service is performed or replacements are made in accordance with the instructions provided. Expendable parts of this equipment are similarly warranted to be free from functional defects in materials and workmanship and to conform to the description of this equipment contained in this manual and any accompanying labels and/or inserts. The foregoing warranties shall not apply if the equipment has been repaired other than by MTG or a service facility designated by MTG, or if this equipment has not been operated and maintained in accordance with written instructions provided by MTG, or has been altered by anyone other than MTG, or if the equipment has been subject to abuse, misuse, negligence or accident.

MTG's sole and exclusive obligation and the Buyer's sole and exclusive remedy under the above warranties is limited to repairing or replacing, free of charge, at MTG's sole discretion, the equipment or part which is telephonically reported to be a problem to the local MTG Branch Location, and which if so advised, is returned with a written statement of the observed deficiency, not later than seven days after the expiration of the applicable warranty, to the Matheson Tri-Gas Equipment Technology Center during normal business hours, transportation charges prepaid, and which, upon examination, is found to comply with the above warranties. Return trip transportation charges for the equipment or part shall be paid by the Buyer.

**MTG SHALL NOT BE OTHERWISE LIABLE FOR ANY DAMAGES INCLUDING BUT NOT LIMITED TO INCIDENTAL DAMAGES, CONSEQUENTIAL DAMAGES, OR SPECIAL DAMAGES, WHETHER SUCH DAMAGES RESULT FROM NEGLIGENCE, BREACH OF WARRANTY OR OTHERWISE.**

**THERE ARE NO EXPRESS OR IMPLIED WARRANTIES WHICH EXTEND BEYOND THE WARRANTIES HEREINABOVE SET FORTH. MATHESON MAKES NO WARRANTY OF MERCHANTABILITY OR FITNESS FOR A PARTICULAR PURPOSE WITH RESPECT TO THE EQUIPMENT OR PARTS THEREOF.**

**ACCEPTANCE OF THE EQUIPMENT BY THE FINAL BUYER INDICATES THE FINAL BUYER'S ACCEPTANCE OF ALL WARRANTIES AND LIMITATIONS SET FORTH ABOVE.**

---

## USER RESPONSIBILITY

---

This equipment will perform in conformity with the description thereof contained in this manual and accompanying labels and/or inserts when installed, operated, maintained and repaired in accordance with the instructions provided. This equipment must be checked periodically, with the frequency of such inspections depending upon the scope of use. Damaged, worn or contaminated equipment should not be used. Parts that are broken, missing, plainly worn, distorted or contaminated should be replaced immediately. Should such repair or replacement become necessary, MTG recommends that a telephonic or written request for service advice be made to the MTG Equipment Engineering Group in Montgomeryville Pennsylvania or to the nearest MTG Branch location.

This equipment or any of its parts should not be altered without the prior written approval of MTG Equipment Engineering Group. The user of this equipment shall have the sole responsibility for any malfunction which results from improper use, faulty maintenance, damage, improper repair or alteration by anyone other than MTG or a service facility designated by MTG. Further, the ultimate user of the equipment is responsible for the training and safe operation of the equipment by personnel in his/her employ.

---

## GENERAL SERVICE

---

A unit which is not functioning in a normal manner should be removed from service until such time that repairs or replacement can be made. Upon completion of repair, full testing should be performed to assure the user that the regulator has been returned to its original operating parameters. MTG offers a repair service to its customers for all products that MTG sells. To arrange for repair service, call 215-641-2700 and ask for the Warranty Administrator. **NO PRODUCT WILL BE RECEIVED BY MTG WITHOUT INDICATION OF GAS SERVICE AND WITHOUT PROPER RETURN MATERIAL AUTHORIZATION PROVIDED BY THE WARRANTY ADMINISTRATOR. (All repairs must be made by MTG or an assigned and approved facility to maintain any warranties or guarantees)**

If the unit is under an applicable warranty, return the unit to Matheson for repair or replacement. To arrange for warranty service, call 215-641-2700 and ask for the Warranty Administrator. **NO PRODUCT WILL BE RECEIVED BY MATHESON WITHOUT INDICATION OF GAS SERVICE AND WITHOUT PROPER RETURN MATERIAL AUTHORIZATION PROVIDED BY THE WARRANTY ADMINISTRATOR.**

If advised by the Warranty Administrator to return the product to MTG, prepare the product for shipment and write, in large lettering the RMA Number assigned by the Warranty Administrator on the outside of the box. Also, if required by the Warranty Administrator, supply the completed RMA form with the product. Make sure that the product is adequately packaged, in the original shipping container if possible, and shipped prepaid (MTG will not accept COD freight) with a description of the observed deficiency to the attention of the:

Matheson Tri-Gas  
RMA# \_\_\_\_\_  
166 Keystone Drive  
Montgomeryville, PA 18936

The user is expected to periodically inspect the product for leaks, loose or worn parts, broken or non-functioning components and to address those situations immediately. If the user would require verbal assistance in ascertaining the potential of a problem with any MTG product, contact the local Matheson branch for assistance or your MTG Sales Representative.

---

## SAFETY PRECAUTIONS

---

1. Many Specialty Gases are hazardous in nature. It is important that the user of the equipment carefully review the hazards associated with the gas to be used with the manifold. **BEFORE INSTALLING THE MANIFOLD FOR USE WITH ANY CYLINDER OF COMPRESSED OR LIQUIFIED GAS, REFER TO THE MSDS THAT WAS SHIPPED WITH THE GAS, OR ON FILE IN YOUR FACILITY, AS TO THE SPECIFIC HAZARDS ASSOCIATED WITH THE GAS TO BE USED. ALSO, REFER TO ALL APPLICABLE INSERTS CONTAINED WITH THE EQUIPMENT FOR ADDITIONAL PRECAUTIONS AND OPERATING INSTRUCTIONS.**
2. Before using any manifold on toxic, corrosive, pyrophoric, flammable or other type of hazardous gas, test the leak integrity of the manifold using an inert gas.
3. Make certain that the manifold purchased is suitable for the application intended. All manifolds supplied by MTG have a serial number, a model number, and a pressure limitation label and/or stamping. Carefully review this information to establish the system fit for service in the desired application.
4. Make certain that the equipment purchased or delivered to the ultimate end user conforms to the specifications of the user. The user is responsible for selecting equipment compatible with gases that are to be used, physical parameters of operation and performance and normal material compatibilities. Selection information can be found in MTG Catalogs, MTG Tech Briefs and in the MTG Gas Data Book. In addition, any MTG representative would be pleased to aid in the selection of specific equipment.

5. Before installation of the manifold for use with cylinders of compressed or liquified gas, carefully inspect the manifold for visible signs of damage or contamination. Close attention should involve visual inspection of all exposed and connecting threads for visible signs of wear and abuse. Also examine the manifold for any loose parts outside of those that must swivel for connection to gas cylinder(s), pigtail(s) to manifold(s), outlet line(s). Also examine the manifold for signs of contamination with dirt, grease or any other foreign material. Close attention should be given to the external appearance and the views of the manifold from all inlets and the outlets. If any foreign materials are present and cannot be removed easily with a cloth, or if the threads of any connection to the manifold appear to be abused as indicated above, or any of the components appear to be loose, return the manifold immediately for service.
6. Before connection of the manifold with cylinders of compressed or liquified gas, move the cylinder(s) to the work location and secure the cylinder before removing the cylinder valve cap. Check the cylinder valve as in step 5 for possible contamination and defective or loose parts. If for any reason the cylinder appears to be faulted as noted here, return the cylinder cap to the top of the cylinder, tighten down and remove the cylinder from the work area and call the supplier of the cylinder for immediate pick-up.
7. When using any hazardous gas, the cylinder(s) of the gas should be placed under an exhaust hood or be placed in a suitable safety enclosure.
8. Before connection of the manifold with cylinders of compressed or liquified gas, make certain that the CGA connection on the cylinder matches the CGA connection attached to the pigtails (if provided) of the manifold. CGA connections are fitted to the pigtails to limit the services in which the manifold can be used. **THE USE OF ADAPTORS OR ALTERATIONS TO THE MANIFOLD TO CHANGE SERVICES CAN BE EXTREMELY DANGEROUS AND SHOULD NOT BE ATTEMPTED.** If a conversion of a product is required, consult MTG before attempting.
9. MTG produces and markets several different types of manifolds for use with gases and liquified gases. MTG manifolds are used to increase the capacity of gas needed for a given application by combining the contents of two or more cylinders in a common distribution line. A manifold is to be used with only one gas. Manifolds should not be used for mixing gases, filling gas cylinders (unless the user is licensed for that activity) or refilling empty cylinders not owned by the user.
10. The manifolds should only be used with gases that are compatible with the materials of construction of the manifolds and processes that do not require complete purging of the cylinder connector (pigtail) before and after the cylinder exchange.

## PRODUCT OVERVIEW

The 5M series mini manifolds are available for one to four cylinders.

<b>Standard Features – One-Station Manifold</b>	
<b>Header:</b>	Brass barstock construction
<b>Pigtail:</b>	Flexible hose, PTFE lined, 3 foot long (standard)
<b>Cylinder connection:</b>	CGA nut and tailpiece, brass
<b>Outlet connection:</b>	CGA outlet adapter, brass (standard)
<b>Mounting hardware:</b>	Stainless-steel bracket with holes for 3/8" bolts
<b>Specifications</b>	
<b>Maximum working pressure:</b>	The lesser of 3000 psig or the maximum allowed by the CGA connection.
<b>Operating temperature range:</b>	-65°F to 150°F (-54°C to 65°C)
<b>Available CGA - Gases</b>	
320 - Carbon Dioxide/CF4	510 - Fuel gases
326 - Nitrous Oxide	540 - Oxygen
346 - Air	590 - Air/Zero Air/SF6
350 - Hydrogen/Methane/Carbon Monoxide/Flammables	580 - Nitrogen/Argon/Helium/Inerts
<b>Options</b>	
Flex Hoses, 6 foot long	Indicating Pressure Switches
Outlet fittings	3000 psig
1/4" FPT	600 psig
1/4" MPT	PM-24 Annunciator Box
1/2" MPT	CGA options
1/4" Compression	Add Check Valve to CGA fitting
3/8" Compression	Handles on CGA fittings
1/2" Compression	Quick Coupler CGA's
Valves	Other Options
High Pressure Vent	Strut Mounted
Outlet Isolation	Bracket for Two Stage Regulator
Cylinder holders	NFPA label
Cylinder Holder with Strap	
Cylinder Holder with Strap and Chain	

---

## MANIFOLD INSTALLATION

---

1. Determined the appropriate location for the manifold considering both accessibility and safety.
2. Determine the mounting height based on cylinder size and user accessibility. For a recommended mounting height based on 51" tall cylinders is for the outlet to be about 64" above the floor. Adjust accordingly for other size cylinders. The use of a cylinder shelf may be required for shorter cylinders.
3. Using the upper and lower slots on the mounting bracket, secure the manifold to the wall or strut system using 3/8" bolts.
4. Confirm the manifold is securely mounted.

Note: If you have purchased the optional cylinder holder(s), mount the holder to the wall or strut system using 3/8" bolts. For a recommended mounting height based on 51" tall cylinders is for the bracket to be centered 36" above the floor. Adjust accordingly for other size cylinders.

---

## **GAS CYLINDER INSTALLATION**

---

1. Move the cylinder(s) of gas to the work site:
  - a. Secure the cylinder as to prevent accidental toppling.
  - b. Remove the cylinder cap.
  - c. Make certain that the cylinder valve is tightly closed.
  - d. Remove the cylinder plug, if present. If there is any sign of gas leaking through the closed cylinder valve, replace the plug and contact **THE GAS SUPPLIER IMMEDIATELY** to arrange for disposal.
  - e. Inspect the cylinder valve for contamination or abuse.
2. The user should then put on appropriate safety apparel such as, but not limited to, safety glasses and gloves.
3. Close any valves of the manifold by rotating the adjusting knobs or handles in a clockwise direction.
4. Connect the pigtail(s) to the cylinder valve(s). Always use an open ended or adjustable wrench. Always use a backup wrench on CGA connections. Be aware of the following precautions:

**DO NOT FORCE.** The connection should thread easily. If it cannot be threaded easily, most likely the user has the wrong pigtail connection for the gas service.

**LEFT HAND THREADS** are used on some CGA connections. Notches in the middle of the hex nut usually identify left hand threads.

**GASKETS** are used in conjunction with some CGA connections. If the connection requires a gasket, one has been supplied with each pigtail. Inspect the gasket for signs of contamination and abuse. Do not over-tighten the connection using a gasket as this will force the gasket to extrude into the gas stream.

**NEVER USE LUBRICANTS OF ANY TYPE** on the CGA connection to aid in connection.

**NEVER USE TEFLON TAPE** to aid in the sealing of the CGA fitting to the cylinder valve.

5. Complete the installation of the regulator or switchover at the outlet adapter of the manifold if this has not already been done. Follow the same precautions listed above for the CGA connections.
6. Before operation of the manifold and associated equipment, **IT IS STRONGLY RECOMMENDED** that the user leak check the entire system to be pressurized using an inert gas and an approved method.



---

## START-UP AND OPERATION

---

1. Confirm that all valves are closed as described in "GAS CYLINDER INSTALLATION" section above.
2. The user should then put on appropriate safety apparel such as, but not limited to, safety glasses and gloves.
3. The user should be positioned with the cylinder between themselves and the manifold. **DO NOT REST HANDS ON OR APPLY FORCE TO THE PIGTAIL DURING THE FOLLOWING CHARGING OPERATIONS.**
4. To avoid damage to the manifold's internal parts, open the cylinder valve(s) SLOWLY to allow gas into the system. Open the valves only partially.
5. Observe all high pressure connections in the pressurized system for leaks:

An approved soap solution, if compatible with materials and applications in use, can be used to check connections for leaks.

An approved leak detecting device can be used to check for leaks. Consult the manufacturer's instructions for applications and hazards associated with the gas to be used in the system.

If a leak is indicated, by any of the methods listed above, recheck the CGA connection to the cylinder and all other high pressure connections.

6. If the system has been leak checked and is found to be acceptable, open the cylinder valve(s) completely, then close ¼ turn (**UNLESS THE MANIFOLD IS TO BE USED IN ACETYLENE SERVICE,**) in order to form a good seal within the cylinder valve. Keep the hand wheel or wrench (if required for this particular cylinder valve type) available at all times to allow for prompt shut-off in emergency situations.

---

## CYLINDER REPLACEMENT AND SHUT-DOWN

---

### Changing Depleted Cylinders

1. After the cylinder(s) connected to the manifold have been depleted, determined by the loss of original cylinder pressure within the system or by the loss of weight when using a liquified gas, perform the following steps for cylinder replacement.
2. Turn all valves on the manifold to the off position by rotating the hand knob or lever clockwise until it stops.
3. Close all of the cylinder valves completely on the expended cylinders.
4. If possible, vent the manifold of any residual gas in the system.
5. Disconnect the pigtail(s) from the cylinder by slowly loosening the cylinder connection. Some residual pressure in the pigtail may escape if there is no check valve in the pigtail. Listen for continuous gas seepage. If leaking is evident, re-tighten the cylinder connection immediately and check the cylinder valve for proper closure. If the cylinder valve is in the closed position, and the manifold has been drained of all gases, but leaking persists, contact the GAS SUPPLIER immediately and notify him of the situation.
6. Replace the plug into cylinder valve outlet (where applicable). Replace the cap on the cylinder over the valve. Remove the cylinder from the work place and put the cylinder into a safe storage area. Replace the empty cylinder with a new one per the GAS CYLINDER INSTALLATION section.

### Manifold Shutdown

1. Shut off the gas cylinder valve(s) completely.
2. Shut down any additional gas supplies that may be supplying gas to the system.
3. Open the system and allow the gas to vent from the system in a safe manner consistent with the user's experience or safety requirements.
4. Purge the manifold when necessary in a safe manner consistent with the user's experience or safety requirements.
5. Isolate the manifold from the line system and downstream equipment.
6. For a long term shutdown, disconnect the pigtails from the cylinders, close and cap the cylinder valve, and store the cylinders in a safe location as dictated by your facility's cylinder handling procedures.

# MINI MANIFOLD DRAWING

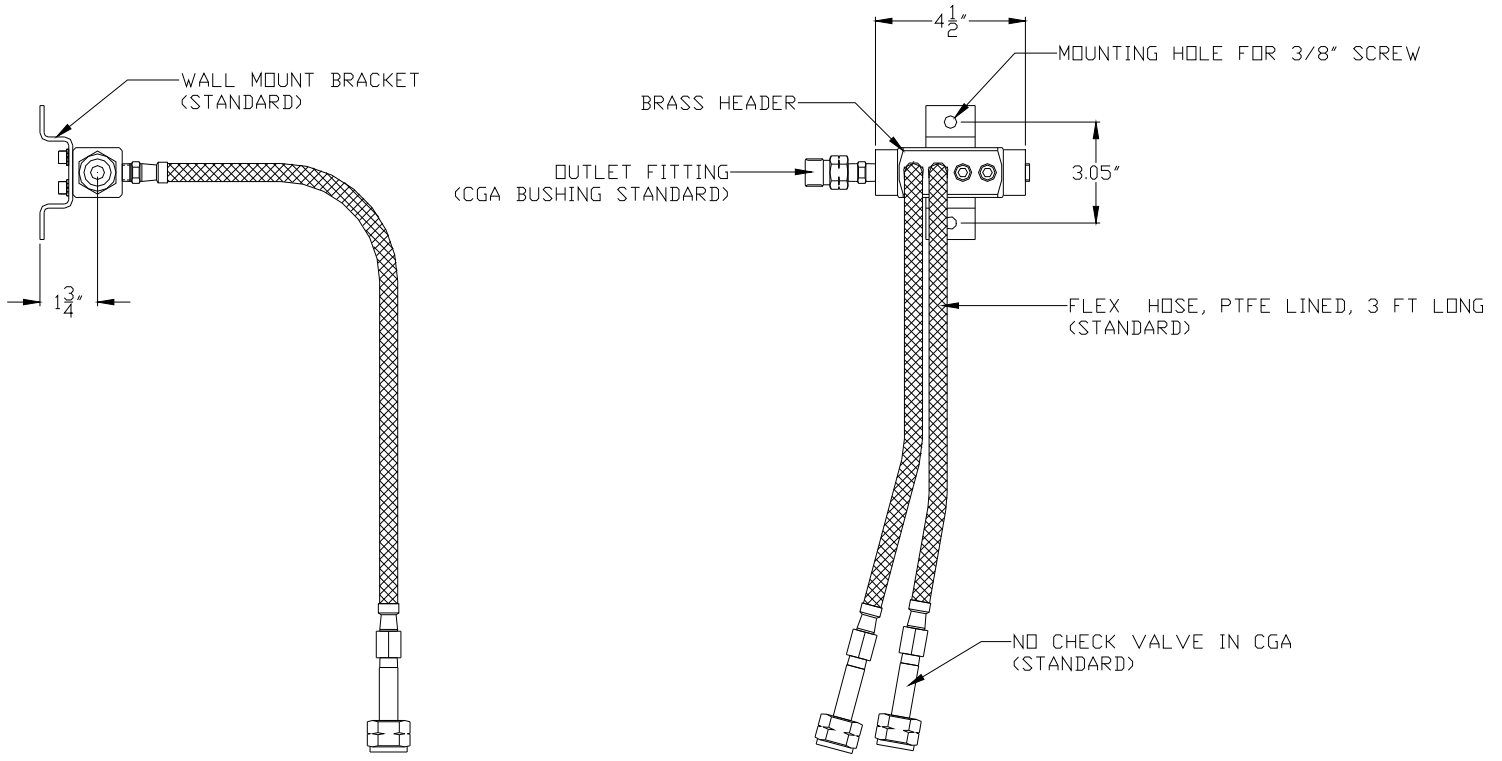

# COMMON OPTIONS

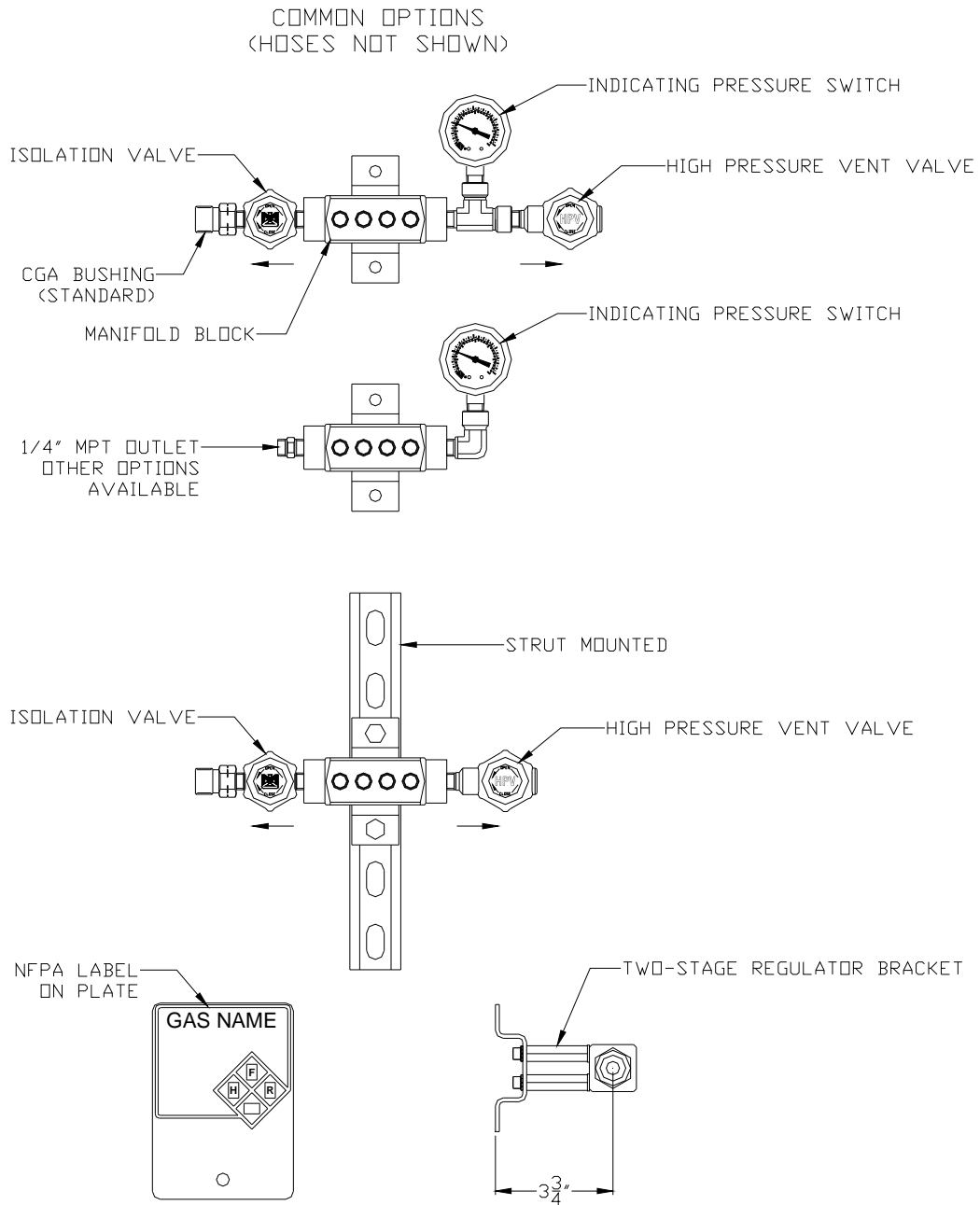

# HOW TO ORDER

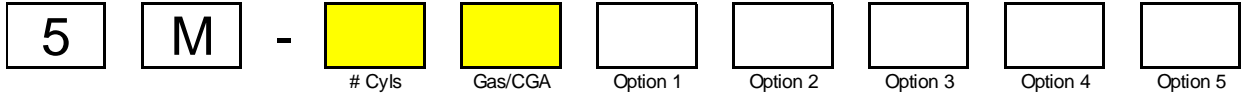

- 1 A 510 - Acetylene
- 2 B 590
- 3 C 510
- 4 F 346
- N 326
- P 540
- T 580
- V 350
- W 320

IPS - Indicating Pressure Switch  
(Gauge with Pressure Switch) -----

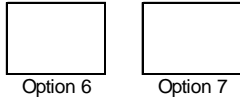

**Typical**

- Brass block and brass fittings
- 3 ft long Teflon lined flex hoses
- CGA's - No check valve
- CGA bushing outlet for cylinder regulator attachment
- Mounting bracket for single stage regulator

1	-----
2	-----
3	6 ft Flex Hose - TEFLON lined
4	Cylinder Holder w/Strap
5	Cylinder Holder w/Strap & Chain (Flammables)
6	No Outlet Fitting (1/4" fpt)
7	1/4" Compression Fitting - Outlet
8	1/4" MPT - Outlet
9	1/2" MPT - Outlet
A	HPV (High Pressure Vent Valve)
B	3/8" Compression Fitting - Outlet
C	1/2" Compression Fitting - Outlet
D	IPS (3000 psig)
E	-----
F	IPS (600 psig) (Not CGA 350)
G	Add Check Valve to CGA fitting
H	Add handles to CGA fittings
I	-----
J	PM-24 Annunciator Box (need D or F)
K	-----
L	Outlet isolation valve
M	-----
N	-----
O	-----
P	Strut Mounted (12" Long Aluminum)
Q	Bracket for two stage regulator
R	Add NFPA label (must specify gas)
S	-----
T	-----
U	-----
V	-----
W	-----
X	-----
Y	-----
Z	Quick Coupler CGA's (Not CGA 350)