



TABLE OF CONTENTS

SECTION 1	General Information: Model Description Serial Numbers Description of Operation	Pg 2
SECTION 2	Safety Instructions: Installation Safety Operation Safety	Pg 3
SECTION 3	Specifications: Flows, Connections, Dimensions, and Weights	Pg 3
SECTION 4	Installation Parts Included Location Install Filters Mounting Electrical Connections Piping and Connections	Pg 4
SECTION 5	Start-Up	Pg 5
SECTION 6	Maintenance	Pg 5
SECTION 7	Replacement Parts	Pg 6
SECTION 8	Troubleshooting Guide	Pg 7
SECTION 9	Wiring Diagram	Pg 8
SECTION 10	Warranty / Claims	Pg 8

SECTION 1 GENERAL INFORMATION

1.1 MODEL DESCRIPTION

The FTIR-PG28 Purge Gas Generator is designed to remove water and CO₂ from a compressed air stream. This is done by passing the air through beds of adsorbent media (13X molecular sieve) which adsorbs both H₂O and CO₂.

1.2 SERIAL NUMBER CODING

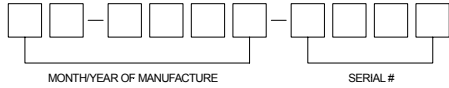

1.3 DESCRIPTION OF OPERATION

The FTIR-PG28 Purge Gas Generator uses the pressure swing adsorption method of gas separation. This requires two identical towers containing beds of adsorbent desiccant media.

Incoming wet, CO₂ rich air enters the adsorber/dryer through the inlet port, where energized SOLENOID VALVE A directs the pressurized air stream to the bottom of DESICCANT TOWER A containing active adsorbent. This adsorbent media bed removes water vapor and CO₂ gas from the air to better than -100°F dew point and less than 1 PPM CO₂ when operated at catalog conditions. The dry and CO₂ free air leaving the top of DESICCANT TOWER A is directed to the outlet through open CHECK VALVE A. PURGE ORIFICE B and closed CHECK VALVE B allow a metered portion of the processed air to flow into DESICCANT TOWER B being regenerated. The open purge port on deenergized SOLENOID VALVE B and the purge orifice reduce the pressurized dry air down close to atmospheric pressure and regenerate the adsorbent media by removing the accumulated water vapor and CO₂ and carrying it out the open purge port.

The two solenoid valves are controlled by a solid state timer. After 30 seconds, the media in DESICCANT TOWER B is regenerated, and the solid state cycle timer causes the process to instantly reverse, with TOWER B adsorbing and TOWER A regenerating. The following flow schematic (FIG 1) demonstrates the adsorber/dryer operation.

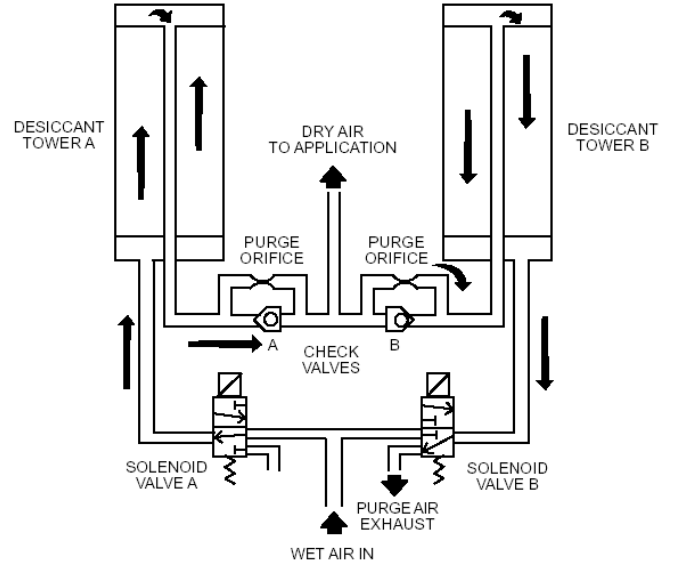

FIG 1

SOLENOID VALVE TIMING CYCLE

30 seconds per side continuous

1 minute total cycle time

SECTION 2 SAFETY INSTRUCTIONS

2.1 INSTALLATION SAFETY

Before starting or installing the FTIR-PG28 Purge Gas Generator, be sure that all power to the unit is off, valves are shut, and the air circuit is at atmospheric pressure. DO NOT remove, repair, or replace any component, control filter, or part, while the unit is energized or the air circuit is under pressure. Unplug unit and de-pressurize the unit before starting installation or maintenance procedures.

The FTIR-PG28 is rated NEMA 1.

2.2 OPERATION SAFETY

DO NOT OPERATE THE FTIR-PG28 PURGE GAS GENERATOR AT COMPRESSED AIR PRESSURES ABOVE 150 PSIG. UNIT FAILURE, INJURY AND EQUIPMENT DAMAGE COULD RESULT

CAUTION:

EXCEPT as otherwise specified by the manufacturer, this product is specifically designed for compressed air service and use with any other gas or liquid is a misapplication. Manufacturer's warranties are void in the event of a misapplication and manufacturer assumes NO RESPONSIBILITY for any resulting loss.

Before using equipment with fluids or gases other than air, consult Matheson Tri-Gas for written approval.

SECTION 3 SPECIFICATIONS

3.1 FLOWS, CONNECTIONS, DIMENSIONS, AND WEIGHT

TABLE 1

MODEL NO.	FTIR-PG28
Max Flow Capacities at 125 PSIG (L/M)	
Inlet Flow	48
Purge Flow	16
Outlet Flow	32
Connections (NPT)	
Inlet	1/4
Outlet	1/4
Dimensions (Inches)	
Height	27.7
Width	17.2
Depth	6.2
Weight (Pounds)	25

OUTLET FLOW CAPACITIES AT VARIOUS INLET PRESSURES WITH PURGE ORIFICE REQ'D		
PSIG	lit/min	orifice no.
150	37.8	18
140	35.5	18
130	33.2	18
120	30.5	18
110	25.5	20
100	23.1	20
90	19.5	20
80	16.6	22
70	13.3	24
60	9.8	26
50	5.7	26

Note: Outlet flows shown above are maximum capacities and should not be exceeded for best performance. No outlet flow metering valve or flow meter is installed on the adsorber/dryer and must be provided by the user. Purge flow is metered by integral fixed purge orifices. Capacities are based on inlet conditions of 70°F, 100%RH, normal ambient CO₂ levels of approx 350-375 ppm. Outlet concentration of CO₂ will be less than 1 ppm and outlet dew point better than -100°F. If your flow, temperature or pressure are different from above, consult factory for performance. **Unless otherwise specified, a #18 orifice set has been installed as standard.**

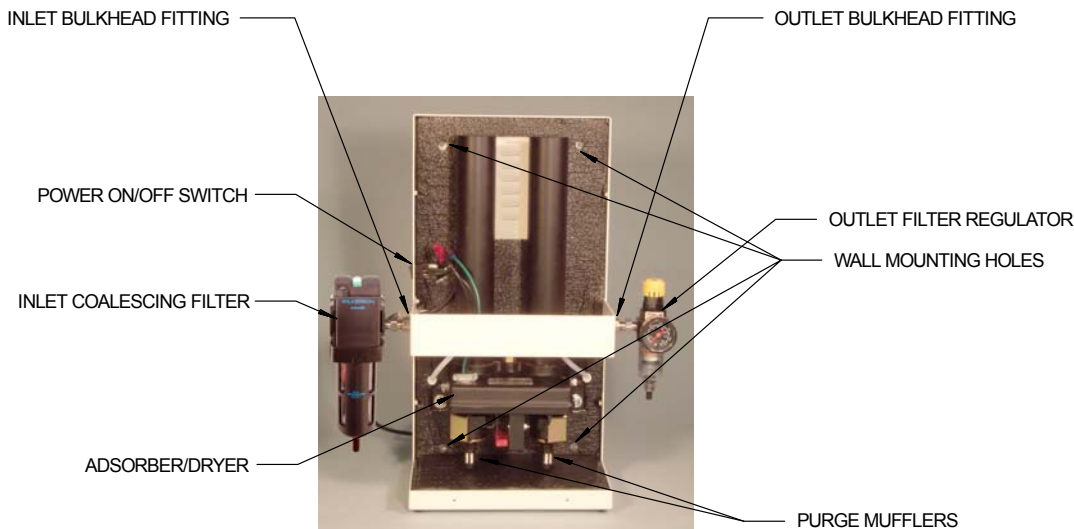

FIG 2

SECTION 4 INSTALLATION

4.1 PARTS INCLUDED

- (1) FTIR-PG28 Purge Gas Generator
- (1) Inlet Coalescing Filter Assy.
- (1) Outlet Filter Regulator Assy.
- (6) Cover Screws, 6-32 x 3/8, PH, SS
- (1) Operations & Maintenance Manual

4.2 LOCATION

DO NOT INSTALL THE UNIT IN AN ENVIRONMENT OF CORROSIVE CHEMICALS, EXPLOSIVE GASES, OR AREAS OF HIGH OR LOW AMBIENT TEMPERATURE (ABOVE 125°F OR BELOW 33°F).

Install the unit indoors. Unit may be wall mounted or placed on a table top.

4.3 INSTALL FILTERS

A coalescing filter is provided to be installed on the inlet to the adsorber/dryer to remove entrained particulates, liquid moisture and oil which can cause damage to the desiccant beds. A particulate afterfilter is provided to be installed on the outlet of the adsorber/dryer to remove any adsorbent media dust that may migrate from the desiccant beds.

Using a wrench to keep inlet bulkhead fitting from turning, install Inlet Filter Assy to left side of unit as shown in FIG 2 above. Similarly, install Outlet Filter Regulator Assy to Right Side of unit.

4.4 MOUNTING

1. Table top
 - a. The unit comes with rubber feet installed on bottom of cabinet for use on table top.
2. Wall mounting
 - a. Remove (6) cover screws and remove cover. While a helper holds the unit at the mounting location, mark the position of the (4) mounting holes at the back of the cabinet. Mount the cabinet using these mounting holes. Be sure to use proper wall mounting anchors if mounting in drywall.
 - b. Reinstall cover.

4.5 ELECTRICAL CONNECTIONS

Before plugging in unit, check the unit nameplate for electrical characteristics. Standard electrical characteristics are 115 volt, 1 phase, 50/60 Hz. Models operating on 230 volts are available.

IMPORTANT!: No overload protection is provided in the adsorber/dryer and unit should be plugged/wired into a protected circuit.

4.6 PIPING AND CONNECTIONS

Inlet and outlet tubing should be appropriate for pressure and temperature of operation. See specification chart for inlet/outlet NPT thread size. Teflon tape should be used in the makeup of joints to ensure a good, airtight fit of piping components. Check all connections for leakage using soap solution prior to putting unit into service.

SECTION 5 START UP

BEFORE UNIT START UP, FOLLOW THE INSTALLATION INSTRUCTIONS AND PROCEDURES COMPLETELY.

DO NOT REMOVE, REPAIR OR REPLACE ANY ITEM ON THE ADSORBER/DRYER WHILE THE ADSORBER/DRYER IS UNDER PRESSURE.

5.1 INITIAL START UPS

1. Confirm that all piping and electrical connections are proper.
2. Turn on the electrical power. Adsorber/dryer should start cycling with a small purge noise heard every 30 seconds.

SECTION 6 MAINTENANCE

DO NOT REMOVE, REPAIR, OR REPLACE ANY ITEM ON THE ADSORBER/DRYER WHILE THE ADSORBER/DRYER IS UNDER PRESSURE.

BEFORE BEGINNING ANY REPAIRS, MAINTENANCE, OR INSTALLATION WORK, VERIFY THAT THE POWER IS OFF AND THE ADSORBER/DRYER IS DEPRESSURIZED.

BEFORE WORKING ON THE ADSORBER/DRYER OR RELATED EQUIPMENT, ENSURE THAT ALL PERSONNEL HAVE READ AND UNDERSTAND THE SAFETY AND OPERATION INSTRUCTIONS IN THIS MANUAL.

6.1 PREVENTIVE MAINTENANCE

Below is a suggested schedule based on average operating conditions. As conditions such as dirty environment, humidity conditions, ambient temperature, etc. change, the frequency of the inspections may need to be increased.

Daily

1. Inspect the adsorber/dryer for proper cycling.
2. Inspect inlet filter for proper drain operation.
3. Verify proper inlet pressure and ambient air temperature conditions.

Semi-Annually

1. Inspect entire assembly for loose connections, screws, etc.

Annually

1. Replace inlet filter elements, outlet filter elements, and purge mufflers:

Inlet Filter	Element
# M18-02-CG00	# MTP-96-646
Outlet Filter/Regulator	Element
# B03-02-G000	#PS403
Purge Mufflers	
#ASN-6 (qty 2)	

SECTION 7 REPLACEMENT PARTS

Part Number	Description (refer to FIG 3)
51448	POWER ON/OFF SWITCH
F14E11B13F	OUTLET FILTER/REGULATOR WITH GAUGE
PS403	- OUTLET FILTER ELEMENT ONLY
P77413	- GAUGE ONLY
F11F16E	INLET FILTER WITH AUTO DRAIN
PS724	- INLET FILTER ELEMENT ONLY
20020	POWER CORD (NOT SHOWN)
ASN-6	MUFFLER, PURGE, 1/8 NPT, (ORDER QTY 2)
51330-0XX	ADSORBER/DRYER INSERT ORIFICE NUMBER FOR XX (SEE TABLE 1 ON PAGE 3 FOR ORIFICES/FLOWS)

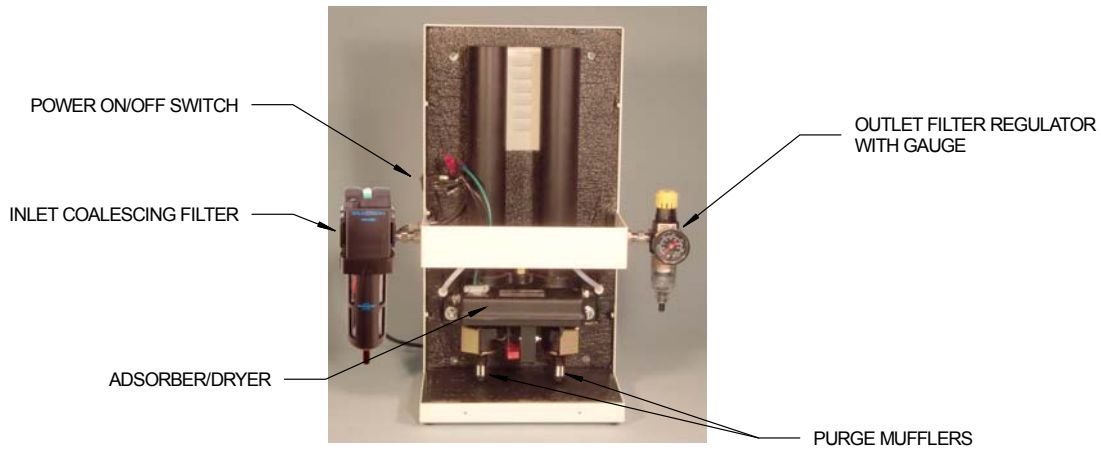
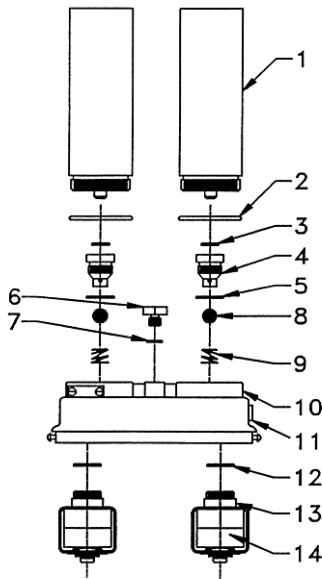

FIG 3



Ref. No.	Part Number	Adsorber/Dryer Part Description (refer to FIG 4)	Qty / Unit	Incl. in Kit (#15)
1	51254	TOWER, 20", 51330 CO ₂ ADSORBER/DRYER	2	
2	-	O-RING, TOWER	2	x
3	-	O-RING, PURGE ORIFICE, INNER	2	x
4	51315-27	PURGE ORIFICE, #27 FOR 140 - 150 PSIG OPER.	2	
	51315-29	PURGE ORIFICE, #29 FOR 120 - 130 PSIG OPER.		
	51315-32	PURGE ORIFICE, #32 FOR 80 - 110 PSIG OPER.		
	51315-40	PURGE ORIFICE, #40 FOR 50 - 70 PSIG OPER.		
(SEE TABLE 1 ON PAGE 3 FOR ORIFICES/FLOWS)				
5	-	O-RING, PURGE ORIFICE, OUTER	2	x
6	51308	MOISTURE INDICATOR WITH O-RING (NOT SHOWN)	1	
7	-	O-RING, MOISTURE INDICATOR	1	
8	51316	BALL, CHECK VALVE	2	x
9	51317	SPRING, CHECK VALVE	2	x
10	51302	MANIFOLD	1	
11	51319	PLUG, MANIFOLD	2	
12	-	O-RING, SOLENOID VALVE	2	x
13	51321	SOLENOID VALVE ASSY, 53 VDC, FOR 115 VAC UNIT	2	
13A	-	CORE, SOLENOID VALVE	2	x
13B	-	BASE, SOLENOID VALVE	2	x
13C	-	FRAME, SOLENOID VALVE	2	x
14	-	COIL (ORDER COMPLETE SOLENOID VALVE ASSY)	2	
15	51325	KIT, MAINT., ADSORBER/DRYER	1	
16	51310	ADSORBER TIMER, CYCLE, FOR 115 VAC UNIT (NOT SHOWN)	1	
17	51313	ADSORBER BOTTOM COVER (NOT SHOWN)	1	
18	51318	ADSORBER BRACKET, MOUNTING (NOT SHOWN)	1	

SECTION 7 TROUBLESHOOTING GUIDE

A PROBLEM: UNIT DELIVERS WET AIR OR HIGH CO₂ LEVELS			
	POSSIBLE CAUSE	CHECK	CORRECTIVE ACTION
A1	High inlet air temperature.	For standard units, inlet air temperature should be 70-80°F.	Reduce inlet air temperature to proper level. An aftercooler may need to be installed after compressor.
A2	Air flow through dryer in excess of rated capacity.	Make sure outlet flow does not exceed rated flow. See capacity chart in SPECIFICATIONS.	Reduce air usage downstream.
A3	Low inlet pressure.	See capacity chart in SPECIFICATIONS.	Increase inlet pressure.
A4	Dirty or obstructed inlet air filter.	Check inlet airline filter elements.	Replace elements.
A5	Purge orifice plugged.	Check purge air flow with flowmeter.	Clean or replace purge orifices.
A6	Solenoid coil burned out.	Check coil leads with ohmmeter. Open (burned out) coil will have no reading.	Replace valves.
A7	Oil contamination of desiccant beds.	Verify particle/coalescing inlet filtration is adequate and functioning properly.	Towers must be replaced if contamination is suspected.
A8	Timing cycle improper.	Verify correct timing cycle by listening to purge or by using voltmeter across coil connections on timer.	Replace timer if defective.
A9	Purge flow restricted.	Check mufflers for excessive back-pressure.	Replace mufflers.

B PROBLEM: RESTRICTED FLOW THROUGH UNIT			
	POSSIBLE CAUSE	CHECK	CORRECTIVE ACTION
B1	No power to unit.	On-Off switch and power supply.	Correct power problem.
B2	Improper operating conditions.	See A2, A3 above.	
B3	Dirty or obstructed inlet air filter.	See A4 above.	
B4	Plugged air passages.	Check inlet and outlet air passages and piping for blockages.	Clear restrictions.
B5	Inlet and outlet ports reversed.	Check inlet and outlet ports for proper connections.	Reconnect properly.

C PROBLEM: EXCESSIVE PURGE			
	POSSIBLE CAUSE	CHECK	CORRECTIVE ACTION
C1	Check valve not closing.	Check for damage or contamination of check valves.	Clean or replace as necessary.
C2	Purge orifice(s) incorrect.	Measure purge flow with flow meter.	Install correct purge orifice(s).

SECTION 9 WIRING

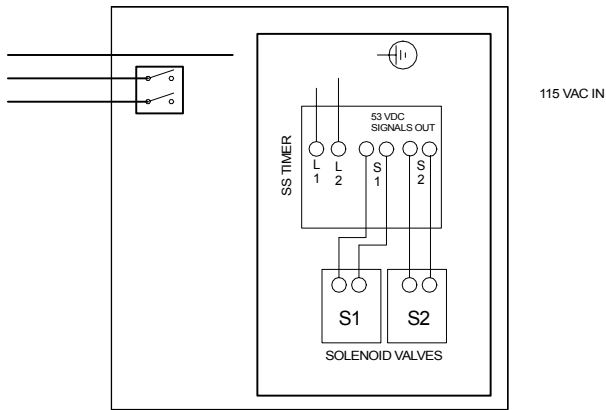

FIG 5

FTIR-PG28 WIRING DIAGRAM

SECTION 10 WARRANTY

Matheson Tri-Gas warrants the FTIR-PG28 Purge Gas Generator to be free of defects in materials and workmanship under proper use, installation and application. This limited warranty shall cover parts or replacement unit only, for a period of 18 months from date of shipment or 12 months from date of installation, whichever comes first.

ALL FREIGHT DAMAGE CLAIMS ARE NOT THE RESPONSIBILITY OF THE MANUFACTURER AND ARE NOT COVERED UNDER WARRANTY AS ALL PRODUCTS ARE SHIPPED F.O.B. SHIPPER. PLEASE DIRECT ALL FREIGHT CLAIMS TO THE FREIGHT CARRIER IN QUESTION.

This warranty does not apply to any unit damaged by accident, modification, misuse, negligence, or misapplication.

Any covered FTIR-PG28 Purge Gas Generator part or material found defective will be repaired, replaced or refunded, at Matheson Tri-Gas's option, free of charge, provided that Matheson Tri-Gas is notified within the above stated warranty period. All returns of defective parts/equipment must have prior written Returned Material Authorization (RMA). RMA may be obtained from our service department. All defective parts/equipment must be returned freight prepaid to the Matheson Tri-Gas factory within 30 days of RMA issue date. Any shipment returned to the factory collect will be refused.

If an item is found to be warrantable, the repaired item or replacement will be shipped via standard ground freight prepaid within the continental US and Canada.

Any replacement part or material is warranted only to the extent of the remaining warranty period of the adsorber/dryer or to the extent as provided by the supplier, whichever is longer.

All freight damage claims should be filed within 15 working days and should be directed to the freight carrier.

Matheson Tri-Gas
166 Keystone Drive
Montgomeryville, PA 18936

Phone: 800-416-2505
Fax: 215-619-0458
Email: info@matheson-trigas.com