



**MATHESON  
TRI•GAS**

ask. . .The Gas Professionals™

# **Hydrogen Generator Model SEPG**

## **Instruction manual**



---

## **MATHESON TRI-GAS**

166 Keystone Drive

Montgomeryville, PA 18936

**Phone: 215-648-4000**

**Fax: 215-619-0458**

**Email: [mtgmmville@matheson-trigas.com](mailto:mtgmmville@matheson-trigas.com)**

# Contents

- INTRODUCTION..... 3**
  - SCOPE OF THE MANUAL ..... 3
  - SPECIFICATIONS ..... 3
  - NOTES ON FCC COMPLIANCE..... 4
  - PACKING LIST ..... 4
- DESCRIPTION..... 5**
- INSTALLATION..... 6**
  - RECEIVING THE GENERATOR ..... 6
  - PLACING THE GENERATOR..... 6
  - GAS CONNECTIONS..... 6
  - ELECTRICAL CONNECTIONS..... 7
  - REMOTE CONNECTIONS (OPTIONAL)..... 8
  - RS-485 IN/OUT CONNECTIONS..... 8
- INITIAL START-UP..... 9**
  - FILLING THE WATER TANK ..... 9
  - INSTALLING THE DEIONIZER BAG ..... 9
  - STARTING THE UNIT ..... 10
- OPERATION ..... 11**
  - LEDS ..... 12
  - LCD DISPLAY ..... 12
  - THE KEYPAD ..... 14
  - CASCADING (OPTION)..... 15
  - SPECIAL FUNCTIONS..... 16
- MAINTENANCE..... 18**
  - ROUTINE MAINTENANCE ..... 18
- TROUBLESHOOTING ..... 19**
  - RETURNING THE UNIT..... 20
- SPARE PARTS LIST ..... 21**

## Introduction

### Scope of the manual

This manual provides operation and maintenance instructions for models SEPG-100, -160, -250 and -500 hydrogen generators.

### Specifications

**Table 1 Specifications of the different models of hydrogen generator**

Hydrogen flow rate	Model SEPG-100	0-100 cc/min at STP
	Model SEPG-160	0-160 cc/min at STP
	Model SEPG-250	0-250 cc/min at STP
	Model SEPG-500	0-500 cc/min at STP
STP	Standard temperature and pressure (STP) = 20°C, 7 barg (100 psig)	
Weight (dry)	SEPG 100 - 160 - 250	16.5 kg
	SEPG 500	18 kg
Power consumption	Model SEPG-100	70VA
	Model SEPG-160	95VA
	Model SEPG-250	140VA
	Model SEPG-500	240VA
Input voltage	117-230V / 50-60Hz	
Pressure accuracy	0.1 barg ( $\pm$ 0.5 %)	
Microprocessor controlled Display	4 rows of 32 characters	
Case dimensions	220 x 330 x 395 mm (WxDxH)	

## Notes on FCC compliance

This equipment has been tested and found to comply with the limits for a Class B digital device, pursuant to part 15 of the FCC Rules. These limits are designed to provide reasonable protection against harmful interference in a residential installation. This equipment generates, uses and can radiate radio frequency energy and, if not installed and used in accordance with the instructions, may cause harmful interference to radio communications. However, there is no guarantee that interference will not occur in a particular installation.

If this equipment does cause harmful interference to radio or television reception, which can be determined by turning the equipment off and on, the user is encouraged to try to correct the interference by one or more of the following measures:

- Reorient or relocate the receiving antenna.
- Increase the separation between the equipment and receiver.
- Connect the equipment into an outlet on a circuit different from that to which the receiver is connected.
- Consult the dealer or an experienced radio/TV technician for help.

### **WARNING!**

*Any changes or modifications to this equipment not expressly approved by the manufacturer may void the user's authority to operate the equipment.*

## Packing list

**Table 2** *List of items included in the shipment*

Quantity	Description
1	Hydrogen generator
1	Instruction manual
1	Deionizer bag
1	Water drain with flexible tubing
1	Power cable

## Description

The hydrogen generator produces pure hydrogen (and oxygen as a by-product) by the electrolysis of water. The key element of the generator is an electrochemical cell assembly which contains a solid polymer electrolyte. No free acids or alkalines are used. De-ionized or pure, distilled water is the only liquid which may come into contact with the cell. As this is consumed it must be refilled from time to time as required.

The generated hydrogen gas is accumulated in the hydrogen/water separator and the desiccant housing. The pressure is controlled by a pressure transducer. The output pressure is indicated on the display. The hydrogen is dried by passing it through a drying tube and a desiccant cartridge containing desiccant material. The hydrogen then passes through the shutoff valve and exits the generator through the outlet port at the rear.

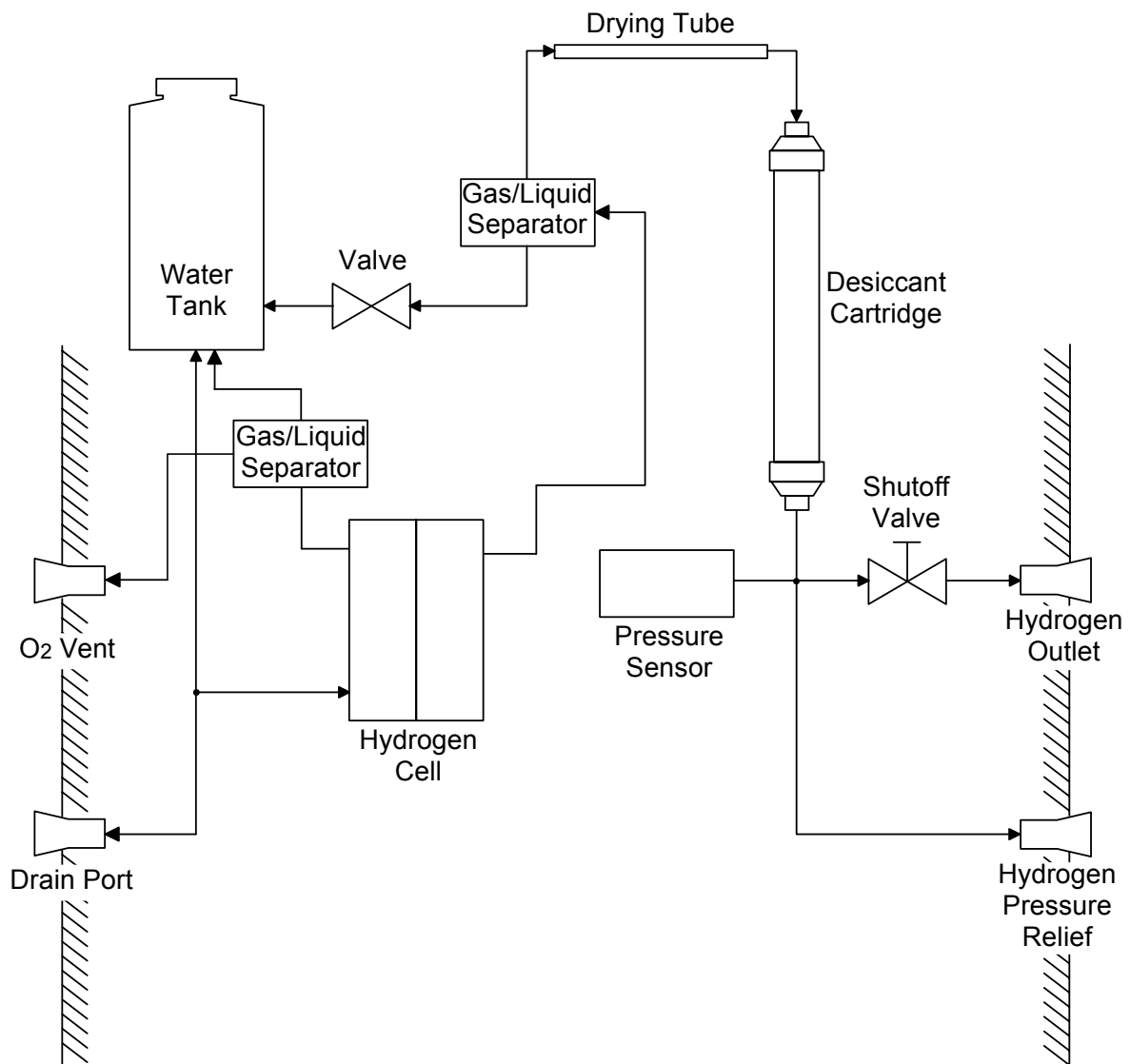

**Figure 1** Hydrogen generator flow chart

## Installation

### Receiving the generator

All units have been carefully inspected before transport. Visual checks for damage and functional tests should be performed upon receipt. Any damage must be immediately noted and reported. The generator must only be returned according to the shipping instructions provided.

### Placing the generator

The hydrogen generator must be placed on a flat, level, vibration-free, shock-free surface. Do not place the generator over a source of heat, as this may cause the device to overheat. The unit should not be in contact with any other objects on any side, and the air inlet must not be blocked. Do not operate the generator in a sealed or unventilated room, or in close proximity to open flame or other sources of ignition. Do not operate the generator at below freezing temperatures. Operation is guaranteed at operating temperatures between +15 and +40°C.

#### **WARNING!**

*Normal precautions for any hydrogen supply should be taken when using the generator. DO NOT use in sealed or unventilated rooms. DO NOT use in close proximity of open flames or other sources of ignition.*

### Gas connections

Pure dry hydrogen at regulated pressure is available at the hydrogen outlet port at the rear of the generator. This port must be connected to 1/8" tubing using a stainless-steel or copper Swagelok connector. Teflon connectors are not suitable. The pressure at this port is adjusted and shown on the display. The hydrogen relief port at the rear of the unit can be connected to an exhaust hood or other vent system.

#### **IMPORTANT!**

*Remove the plug from the oxygen vent before operating the unit. Keep this plug for transporting the unit.*

#### **WARNING!**

*The line from the relief port should never be connected in such a way that back pressure can develop.*

**Electrical connections**

Check the setting of the voltage selector on the rear of the unit. The set voltage is indicated by the white arrow. To change the voltage, proceed as follows:

- Using a small screwdriver, remove the voltage selector insert.
- Replace the voltage selector insert so that the white arrow points to the correct voltage.

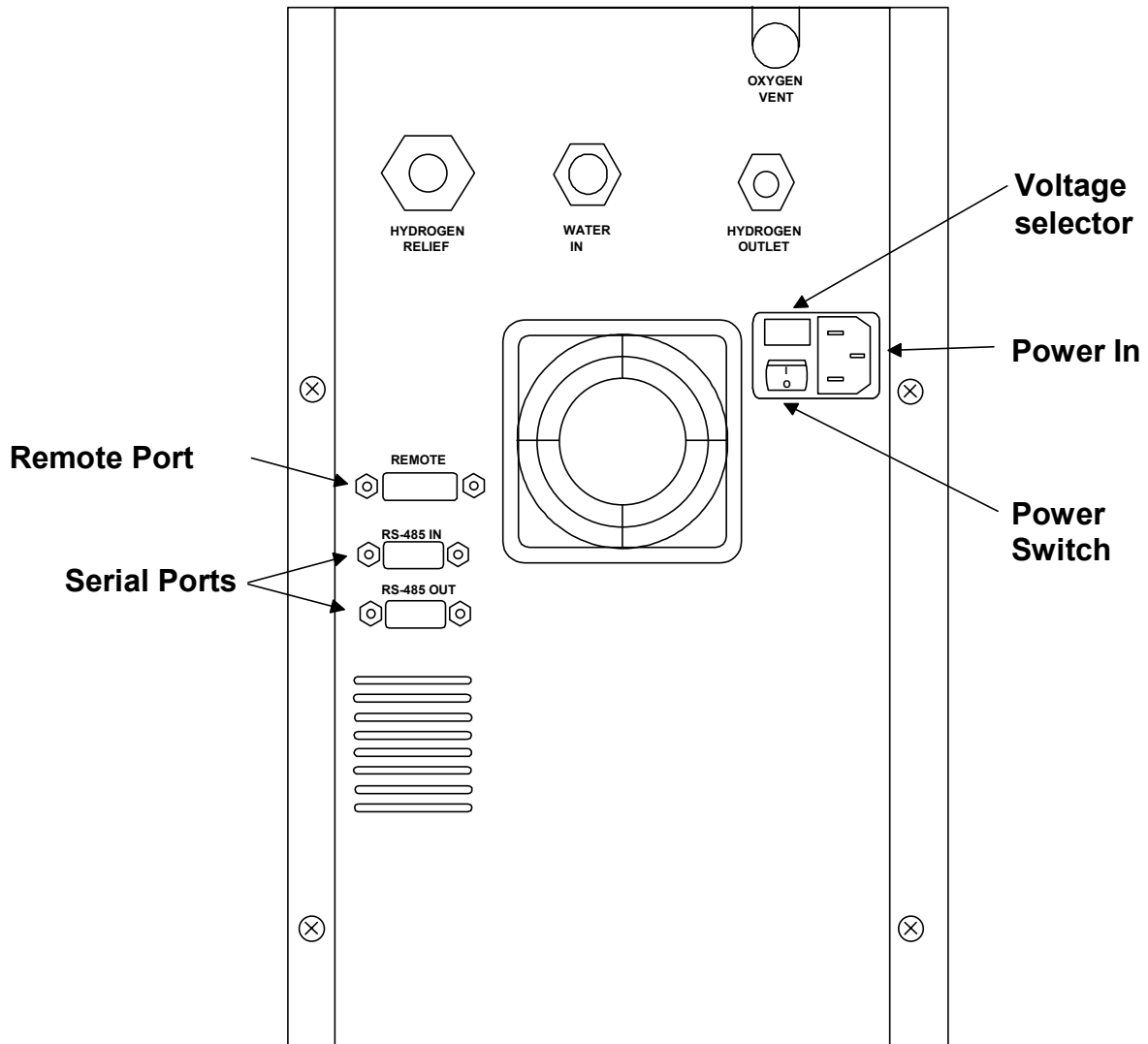

**Figure 2 Hydrogen generator - rear view**

### Remote connections (optional)

The hydrogen generators are fitted with an optional remote control feature, which allows the user to check the status of the machine from a remote position, and to start/stop the production of hydrogen.

The contacts used in the remote control are potentially free relay contacts. The contacts can be configured via software as normally-open or normally-closed (see the *Configuration* section). The maximum voltage and current ratings for the contacts are **1A / 48V**. The pin configuration of the remote connector is shown in the table below.

**Table 3 Remote connector pin configuration**

Pin	Description
1+2	Start (12-30 VDC polarity not important)
3+4	Standby (System not OK)
5+6	Reaching normal pressure (Overproduction)
7+8	Refill water (Low water)
9+10	Low water level (Too low water)
11+12	Bad water
13+14	Change water (Bad water pre alarm)

### RS-485 IN/OUT connections

Only used for the Cascading option. See page 15.



## Initial start-up

### Filling the water tank

To fill the water, remove the cap on the water tank. Carefully fill the tank with distilled or de-ionized water. The conductivity of the water used in the generator must not exceed  $2\mu\text{S}$ .

Fill the tank to the maximum level indicator. Replace the cap, and the leave the small hole free for ventilation.

**WARNING!**

*Do not fill the water tank higher than the marked level.*

**CAUTION!**

*To prevent contamination of the cell assembly, it is important to use only deionized or distilled water in the generator. Water containing metallic impurities will contaminate or damage the cell, and will void the warranty.*

### Installing the deionizer bag

After having filled the tank with water, the deionizer bag (supplied) must be placed in the tank. Inspect the bag thoroughly for holes or tears, indicated by loose deionizer beads on the outer surface. If the bag is damaged in any way, discard and replace it with a new one. Only use original parts (see *Spare Parts*). Wash the deionizer bag in deionized water before proceeding.

Insert the free end of the "T" fastener through the hole in the centre of the water filler cap, until it is securely fastened. The bag should not block the outlet at the bottom of the tank. Once in place, the bag should not be allowed to dry out.

**Starting the unit**

Once all of the previous operations have been performed, the generator is ready for operation.

1. Close the **Shutoff Valve** located on top of the unit, next to the water tank cap.
2. Check that the tank is filled with deionized water.
3. Check that the hydrogen outlet connector is tightly fitted.
4. Check that the plug has been removed from the oxygen vent.
5. Turn the **Power** switch to the ON position.
6. Enter the desired set pressure, using the **arrow** buttons on the keypad.
7. Press the **Start** button to start the unit (if the unit has been configured for "Auto Start" - see *Configuration* - it will start automatically).
8. The unit will immediately begin to build up pressure. The LCD display will show the message "Reaching normal pressure", and the H<sub>2</sub> Flow Bar will indicate maximum flow (fully illuminated).
9. Wait until the **Act** pressure reaches the **Set** value. These values are shown on the LCD display. It may take a few minutes to reach the **Set** operating pressure.

**NOTE**  
*If the generator does not build up pressure as required, the unit will shut down. Refer to the Troubleshooting table.*

10. Once the pressure reaches the **Set** value, the LCD display will show the message "Normal pressure" and the H<sub>2</sub> Flow Bar will indicate no flow (no segments illuminated). This indicates that there are no gas leaks within the generator itself.
11. Open the **Shutoff Valve**. The outlet pressure will fall initially. The amount and the duration of this pressure drop is dependent on the volume of the external equipment connected to the generator.
12. After the initial pressure drop, the outlet pressure should stabilise at the **Set** pressure. A continuing drop in pressure indicates a gas leak in the external equipment, or too high hydrogen consumption. Check the external equipment for leaks or too-high consumption.
13. The generator is now in normal operating conditions.

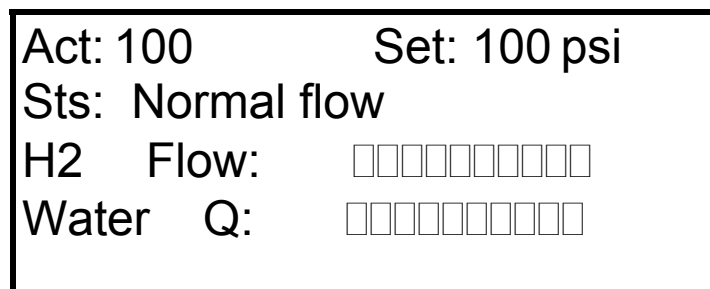

**Figure 3    LCD Display**

Operation

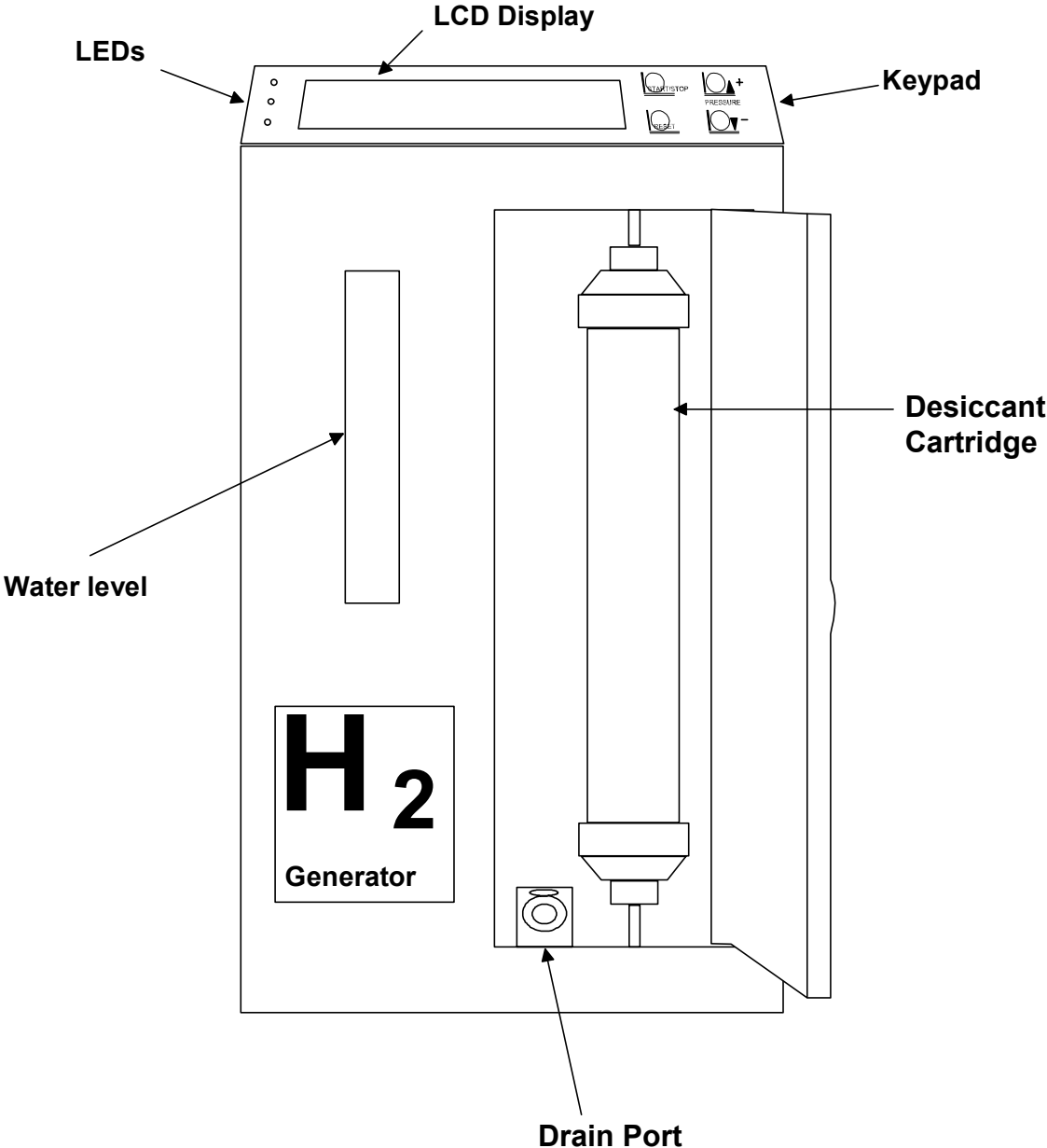

Figure 4 Front view of the hydrogen generator

## LEDs

The unit is fitted with three LEDs, which offer an overall view of the status of the unit.

### **Green LED**

The green LED shows that unit is powered.

### **Yellow LED**

When the yellow LED is on, the unit is producing hydrogen.

### **Red LED**

The red LED shows that unit has shut-down due to an alarm.

## LCD display

All important operating information is shown on the display.

### Layout of the display

The four rows on the display provide the following information.

Act: 100	Set: 100 psi
Sts: Normal flow	
H2 Flow:	□□□□□□□□
Water Q:	□□□□□□□□

### First row, pressure information

**Act** is the actual pressure of the hydrogen, while **Set** is the set pressure.

The pressure can be increased using the **↑** button, or decreased using the **↓** button.

### Second row, status information

**Sts** shows current information on the operating status of the generator.

The information can be divided into 3 groups:

**Information:** displays normal operating status

**Pre-alarm:** indicates that a maintenance intervention will soon be required; accompanied by an audible signal.

**Alarms:** indicates that maintenance intervention is required and that the machine has been shut down; accompanied by an audible signal.

**Table 4** List of messages displayed

Message	Description	Type	Action
Standby	Device ready for H <sub>2</sub> production.	Information	Press start
Reaching Normal Pressure	Device producing H <sub>2</sub> and increasing pressure to the set value	Information	
Normal Pressure	Device producing H <sub>2</sub> and has reached the set pressure value	Information	
Normal Flow	Device producing H <sub>2</sub> and has reached the set pressure value, with H <sub>2</sub> flowing	Information	
Refill Water	Water level approaching alarm threshold	Pre-alarm	Fill the tank with water
Change Water	The conductivity of the water has exceeded 10µs	Pre-alarm	Drain and then refill the tank; change the deionizer bag
Low Pressure	The set pressure can not be reached	Alarm	Check for internal or external leaks. Check max. H <sub>2</sub> consumption
Low Water Level	There is too little water in the tank	Alarm	Refill the tank
Bad Water	The conductivity of the water has exceeded 15µs	Alarm	Drain and then refill the tank; change the deionizer bag
High Cell Voltage	High cell voltage	Alarm	Notify service agent

**Third row, hydrogen flow**

This row displays the current quantity of hydrogen being produced. Each point represents around 10 % of maximum capacity.

This graph also indicates approximately how much hydrogen is being consumed by the connected equipment.

**NOTE**

*The last point on the flow graph will flash only. This indicates that the generator is producing at maximum capacity. In normal operation, this should not be the case, as it indicates that the consumption is too near the maximum limit, and the unit may shut-down if consumption increases further. Maximum flow is normal when the unit is building up pressure.*

**Fourth row, water quality**

This graph shows the quality of the water.

With more than 3 points illuminated, water quality is good.

If only 3 or less points are illuminated, the conductivity of the water is around pre-alarm level.

If only 1 point or no points are illuminated, the conductivity of the water is equal to or greater than alarm. The generator will be shut down.

**The keypad****Start/Stop button**

The Start/Stop button places the generator in normal operating mode from Standby and vice-versa. It is also used to re-start the unit following an alarm. When the problem leading to the alarm has been resolved, the generator must be reset using the Reset button, and then can be started by pressing the Start/Stop button.

**Reset button**

Silences the audible alarm. When the problem leading to the alarm has been resolved, the Reset button must be pressed before the generator can be restarted (also see *Special functions*).

The Reset button is also used to access the special functions.

## Cascading (option)

The RS-485 interface allows up to 10 generators to be operated in parallel mode. One unit has to be defined as the master, while the others operate in "Slave" mode. All the slaves need to be configured with individual ID numbers. Communication between the generators requires a standard D-sub 9 pin serial cable. The serial ports are connected as follows:

Master RS 485 out → Slave 1 RS 485 out - Slave 1 RS 485 in → Slave 2 RS 485 in ....

### Configuration

#### *Configuring the Master*

1. Press and hold the reset button until the display shows "menu". Press the reset button again to enter the configuration menu.
2. Press the Start/Stop button repeatedly until the display shows "Master". Set the value using the +/- button to Yes.
3. Press the Start/Stop button once more. The Display shows "ID Nr". Enter the number of slaves connected to the master using the +/- buttons.
4. Press the reset button twice.

#### *Configuring the Slaves*

1. Press and hold the reset button until the display shows "menu". Press the reset button again to enter the configuration menu.
2. Press the Start/Stop button repeatedly until the display shows "Master". Set the value using the +/- button to NO.
3. Press the Start/Stop button once more. The Display shows "ID Nr". Enter the ID number of the slave. Use a different number for each slave, starting from ID Nr. 1.
4. Press the reset button twice.

The configuration is now complete.

### Operating in Master Slave Mode

Connect the gas outputs of all the generators to the same line. Open all the main valves.

If the configuration and the serial connection is correct, the slaves will shows "Slave Mode" after starting up. Change the pressure setting on the master, and the slaves will follow the master.

#### **IMPORTANT!**

*The cascading function will only work properly if the gas outlets on all the generators are connected together and the main valves are in the open position.*

### Special functions

The unit features a number of special functions that can be configured by the user. The special functions are divided into three sections: *Configuration*, *Diagnostic* and *Alarm history*.

#### Configuration

The configuration parameters allow the user to customise the unit as required.

#### Diagnostic

The diagnostic functions provide additional information on the operating status of the unit.

#### Alarm history

The alarm history displays the last 20 alarms which have been activated.

To enter the special functions, press and hold “Reset” for 3 seconds. The diagram below shows the menu tree to be followed to set or display the various functions.

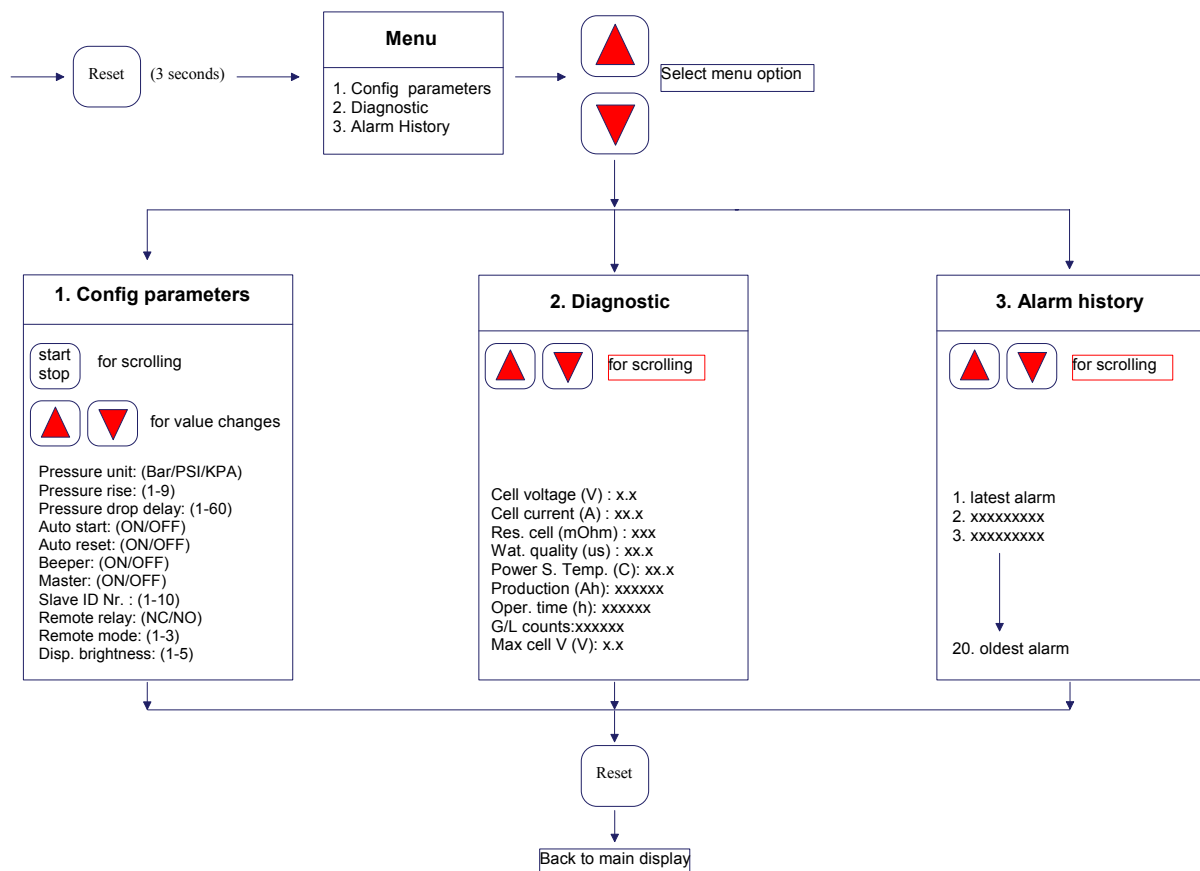

**Figure 5** Menu tree for configuring the special functions



**Configuration parameters**

Item	Description	Default
Pressure unit: (Bar/psi/KPA)	<i>Sets the desired pressure unit</i>	<b>bar</b>
Pressure rise: (1-9)	<i>Sets a reference pressure increase rate for the leak alarm. If the pressure increases at a slower rate, the unit assumes a leak, and shuts down. A low value means a slower rate of increase, and vice-versa.</i>	<b>5</b>
Pressure drop delay: (1-60)	<i>Sets a delay in seconds to override the pressure increase alarm</i>	<b>30</b>
Auto start: (ON/OFF)	<i>Sets whether the unit automatically starts production when power is connected</i>	<b>OFF</b>
Auto reset: (ON/OFF)	<i>Sets whether the Reset button must be pressed following an alarm before the unit can be restarted</i>	<b>OFF</b>
Beeper: (ON/OFF)	<i>Sets whether the audible alarm signal is activated</i>	<b>ON</b>
Master: (ON/OFF)	<i>Sets the unit to master in cascading mode</i>	<b>OFF</b>
Slave ID Nr.: (1-10)	<i>Set the slave ID number in cascading mode</i>	<b>1</b>
Remote relay: (NC/NO)	<i>Configures the remote relay contacts</i>	
Remote Mode : (1-3)	<i>Mode 1 = Start only Mode 2 = Start / Stop Mode 3 = Direct mode (production if control voltage is high)</i>	<b>NC</b>
Disp. brightness: (0-5)	<i>Adjusts the brightness of the display</i>	<b>5</b>

**Diagnostic display**

Item	Description
Cell voltage (V)	<i>Actual cell voltage</i>
Cell current (A)	<i>Actual cell current</i>
Res. cell (mOhm)	<i>Actual cell resistance</i>
Wat. quality ( $\mu$ S)	<i>Actual water conductivity</i>
Power S. temp. ( $^{\circ}$ C)	<i>Actual temperature of the power supply</i>
Production (Ah)	<i>Total current passed through cell (1 Ah = approx. 8 cc of hydrogen production)</i>
Oper. time (h)	<i>Total number of hours the unit operation</i>
G/L counts	<i>Number of switching of the gas-liquid separator valve</i>
Max. cell V (V)	<i>The maximum cell voltage in the life of the cell</i>

**Alarm history**

The alarm history shows the last 20 alarms, in chronological order from the most recent, to the oldest.

## Maintenance

With proper care and maintenance, your hydrogen generator should provide you with years of trouble-free operation. There are no adjustments to be made to the generator. The only routine service operations are those described below.

Nonetheless, the generator should be inspected approximately every 2 years. Contact your supplier or Matheson Tri-Gas directly.

### Routine maintenance

The following section describes the maintenance operations required for the correct operation of the hydrogen generator.

#### Water refilling

The tank must be refilled when the water level approaches the lower level, and the **Refill Water** pre-alarm message appears.

#### Desiccant replacement

Change the desiccant cartridge when the blue colour of the desiccant turns to grey-beige. The colour of the desiccant can be observed through a view port in the front panel of the generator.

To remove the desiccant cartridge: first loosen the top and bottom connectors. These are finger tight; no tools are required. Then extract the cartridge, and replace with a new or re-generated one. Reconnect the cartridge to the tubing and tighten the connectors (finger tight!).

**Return the used cartridge to your reseller for refilling.**

#### Deionizer bag replacement

Rinse the water tank and replace the deionizer bag approximately **every six months**, or whenever the **Change Water** message appears.

#### Installing the new deionizer bag

After having refilled the tank with water, the new deionizer bag must be placed in the tank. Inspect the bag thoroughly for holes or tears, indicated by loose deionizer beads on the outer surface. If the bag is damaged in any way, discard and replace it with a new one. Only use original parts (see *Spare Parts*). Wash the deionizer bag in deionized water before proceeding.

Insert the free end of the “T” fastener through the hole in the centre of the water filler cap, until it is securely fastened. The bag should not block the outlet at the bottom of the tank. Once in place, the bag should not be allowed to dry out.

## Troubleshooting

The unit automatically detects any operating anomalies, and displays a warning message. The troubleshooting guide below provides help in how to resolve the operating anomalies.

**WARNING!**

*Due to the pressure of the gas and the dangerous nature of hydrogen, all service and troubleshooting operations which require the removal of the cover must be performed using suitable protective equipment.*

Message / Symptom	Description	Action
Refill Water	Water level approaching alarm threshold	Fill the tank with water
Change Water	The conductivity of the water has exceeded the pre-alarm level	Drain and then refill the tank; change the deionizer bag
Low Pressure	The set pressure can not be reached	Check for internal or external leaks. Check max. H <sub>2</sub> consumption Check and decrease setting of pressure rise parameter (see <i>Special functions</i> )
Low Water Level	There is too little water in the tank	Refill the tank
Bad Water	The conductivity of the water has exceeded the alarm level	Drain and then refill the tank; change the deionizer bag
High Cell Voltage	High cell voltage	Notify service agent
(No message)	No mains power	Check power cable and socket

## Returning the unit

In the event of any faults or damage, first notify the agent or distributor who supplied the unit. If this is not possible, inform Matheson Tri-Gas directly. Please also provide full details of the problem, including the model and serial number. Instructions will then be provided for the service or the return of the unit. Only if return authorization is provided by Matheson Tri-Gas as per these instructions, will the device be received and repaired by Matheson Tri-Gas. If the one year warranty has expired, or the fault is due to misuse of the unit, all repair and shipping costs are to be paid by the customer. All other costs are borne by the customer, except as otherwise expressly agreed upon.

### **WARNING!**

*If the unit has to be transported, make sure that the water tank is **completely** empty, and place the plug (supplied with the unit) on the oxygen vent at the rear of the unit. Close the small hole in the cap on the water tank with a strip of adhesive tape.*

*Use suitable packaging. The unit should be transported in an upright position; this warning should be reported on the outside of the packaging.*

## Spare parts list

The table below provides a list and description of the replaceable parts of the hydrogen generator. Please also refer to the corresponding figures.

**Table 5** *List of replaceable spare parts*

<b>Part Number</b>	<b>Description</b>
H280302	Filled desiccant cartridge + fittings complete
H280326	Desiccant refill pack (for 3 cartridges)
H280327	Deionizer bag

**IMPORTANT!**

*The manufacturer reserves the right to change or modify its products without prior notice.*