

NANOCHEM® C/CL-Series Gas Purifiers

Features and Benefits

- Purification for all ultra-high purity source or point-of-use applications
- **Highest Lifetimes**
- **Best Impurity Removal Efficiencies**
 - Removes critical contaminants to sub parts-per-billion level (< 0.1 ppb in inert gases)
- **End-Point Detection for most non-corrosive gases**
- Built-in one-valve bypass
- **Ultra-clean construction**
- Enhances manufacturing process economy and improves equipment performance
- Provides consistently high purity gas under fluctuating inlet impurity conditions
- Does not require heating or cooling
- Low overall cost of ownership
- **C-Series provided with protective exhaustible enclosures** that satisfy Uniform Fire Code (UFC) requirements. Suitable for flammable gas service.

Specifications

- Recommended for flow up to 150 slpm (9 NM³/hr)
- All gas-wetted parts constructed of Type 316L stainless steel, Ni 200, Elgiloy®, or Kel-F®
- 0.003 µm particle filter with 99.999999% retention (PTFE or 316L SS)
- Internal surface finish <15 µin R_a
- Maximum operating temperature of 70°C
- Inlet, outlet, and bypass springless diaphragm valves
- Maximum allowable operating pressure of 150 psig (1.13 MPa) with the fiber optic endpoint detector or 500 psig (3.5 MPa) without endpoint detector

Connections

- Female inlet and male outlet 1/4 inch VCR®-compatible face seal fittings

Overview

The NANOCHEM® C/CL-Series Purifiers are designed for "ultra-clean" multi-tool, single-source or point-of-use applications.

NANOCHEM® C/CL-Series Purifiers eliminate virtually all variables that cause contamination. Gas impurities may be present in gas cylinders, and can also be introduced through leaks in the line or during cylinder changes.

The C/CL-Series Purifiers are designed for the highest possible purity. The bypass valve allows purging to ensure no atmospheric contamination enters the purifier. The outlet particle filter is installed downstream of all valves to ensure no particles can escape the purifier. C-Series Purifiers are provided with exhaustible enclosure for use with flammable gases.

Standard purification media bed volumes for the three available C/CL-Series Purifiers are: 300, 500, 2000 ml.

Media refills are available through Matheson Tri-Gas, Inc., for all sizes.



CL-Series

C-500 and CL-500 Pressure Drop as a Function of Flow Rate

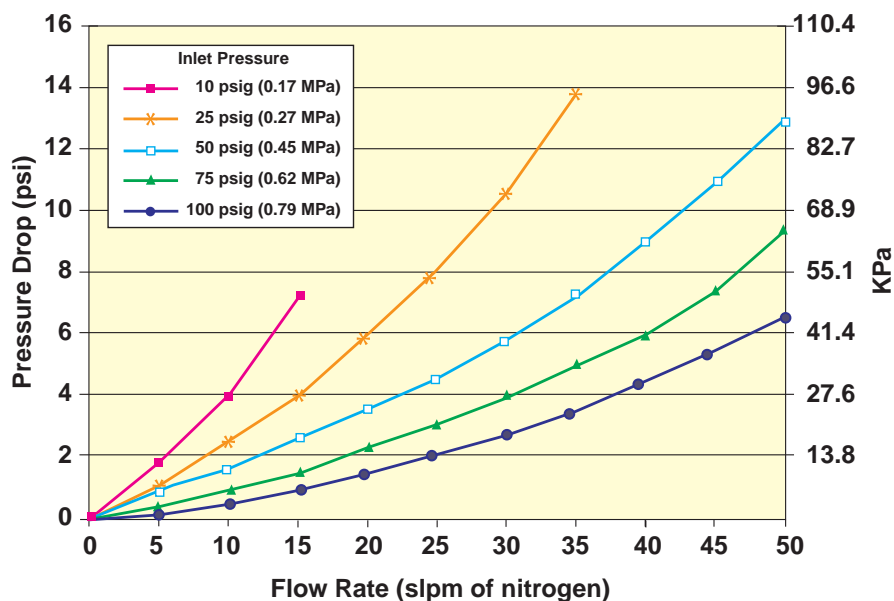

**MATHESON
TRI•GAS**

ask. . .The Gas Professionals™

Dimensions in inches (mm)

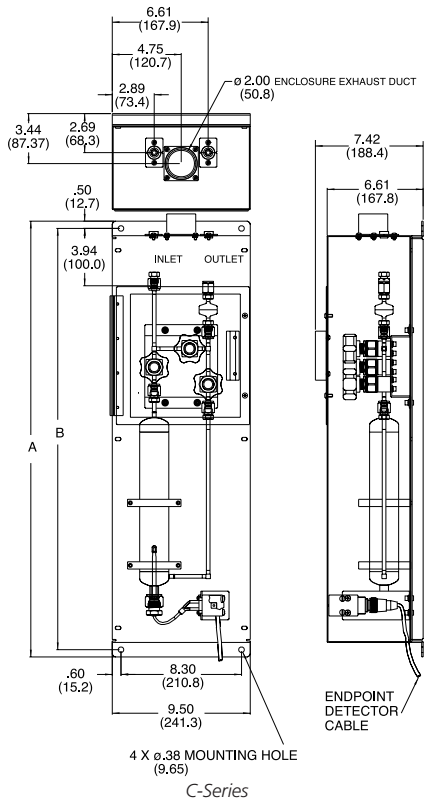

C-2000 and CL-2000 Pressure Drop as a Function of Flow Rate

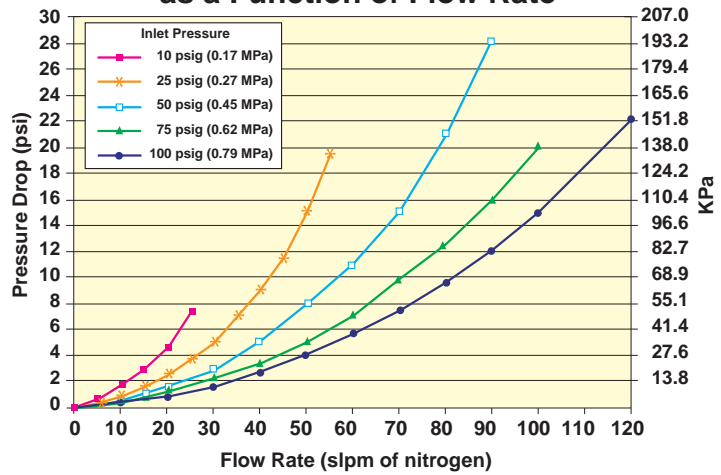

Dimensions inches (mm)		
C/CL-Series Purifiers	C-300/500	C-2000
A	30.00 (762.00)	38.5 (977.90)
B	29.00 (736.60)	37.50 (952.50)

Gas Type	Impurities Removed
Nitrogen (N ₂), Argon (Ar), other inerts	< 0.1 ppb H ₂ O, O ₂ , CO ₂ LDL < 1 ppb CO* < 0.1 ppb NMHC (with OMX-Plus™) LDL NO _x , SO _x , H ₂ S
Ammonia (NH ₃)	< 0.1 ppb H ₂ O, O ₂ , CO ₂ in inert gas LDL < 1 ppb CO* < 45 ppb H ₂ O in ammonia LDL NH ₃ -CO ₂ complexes, SiH ₄ , Siloxanes, GeH ₄ , H ₂ S
Silane (SiH ₄)	< 0.1 ppb H ₂ O, O ₂ , CO ₂ LDL < 1 ppb CO* Chlorosilanes, disilane, siloxanes, arsine, phosphine
Arsine (AsH ₃), Phosphine (PH ₃)	< 0.1 ppb H ₂ O, O ₂ , CO ₂ LDL < 45 ppb H ₂ O in phosphine LDL < 75 ppb H ₂ O in arsine LDL CO, oxyacids (H ₃ AsO ₃ , H ₃ P ₃ O ₇)
Hydrogen (H ₂), Methane (CH ₄), Ethane (C ₂ H ₆), other HC	< 0.1 ppb H ₂ O, O ₂ , CO ₂ LDL < 1 ppb CO* NO _x , SO _x , H ₂ S
Sulfur Hexafluoride (SF ₆), Carbon Tetrafluoride (CF ₄), other fluorocarbons	< 0.1 ppb H ₂ O, O ₂ , CO ₂ in inert gas LDL < 10 ppb O ₂ , H ₂ O in sulfur hexafluoride LDL
Oxygen (O ₂), Carbon Dioxide (CO ₂), Nitrous Oxide (N ₂ O)	< 10 ppb H ₂ O
Carbon Monoxide (CO)	Metal Carbonyls: Fe, Ni
Corrosives (HCl, HBr, Cl ₂ , SiH ₂ Cl ₂ , SiHCl ₃ , BCl ₃)	< 1 ppb H ₂ O in inert gas < 100 ppb H ₂ O in HBr LDL < 150 ppb H ₂ O in HCl Volatile Metals: Fe, Mo, Cr, Ni, Mn, Ti

LDL – Lower Detection Limit by State-of-the-Art Analytical Instrumentation

NMHC – Non-methane Hydrocarbons

*NOTE: CO is removed efficiently by OMX & OMX-Plus™ media at low flow rates (recommend 1/10 of normal flow rate)

For a detailed list of purification media and impurities removed, refer to the Purification Media Table in NANO-CHEM® Purification Solutions Brochure.

Equipment Technology Center

166 Keystone Drive
Montgomeryville, PA 18936
Tel: 800-828-4313 • Fax: 215-619-0458
Email: Info@matheson-trigas.com

Specifications are subject to change. Please check www.matheson-trigas.com for most current information.

MATHESON TRI-GAS and NANO-CHEM are registered trademarks of Matheson Tri-Gas, Inc. Elgiloy is a registered trademark of Elgiloy Corporation.

VCR is a trademark of Swagelok Co. Kel-F is a registered trademark of 3M.

Printed in USA PB029 R05/05



**MATHESON
TRI-GAS**

ask... The Gas Professionals™