

SAGE™ MOCVD / GSMBE

Safe High Capacity Storage of Hydride Gas Sources

Applications

- MOCVD
- GSMBE

Advantages

- Virtually eliminates the potential for catastrophic releases of highly toxic hydride gas
- Reduces the number of cylinder changes
- Provides a highly consistent dopant gas source
- Reduces the capital and operating cost for delivery equipment and safety
- Reduces ventilation costs

Physical Properties

	AsH ₃	PH ₃
Chemical Formula	AsH ₃	PH ₃
Molecular Weight	77.95	34.04
Specific Gravity	2.69 @ 70°F atm	1.28 @ 70°F atm
Specific Volume	4.95 ft ³ /lb (0.31 l/g)	10.47 ft ³ /lb (0.65 l/g)
Toxicity		
TLV/PEL	.05 ppm	0.3 ppm
STEL	—	1 ppm
LC 50	75 ppm	20 ppm
IDLH	3 ppm	50 ppm
LEL	4.0%	1.6%

Overview

SAGE™ gas sources permit the safest possible use of high capacity, high purity arsine (AsH₃) and phosphine (PH₃) gas for Metal Organic Chemical Vapor Deposition (MOCVD) and Gas Source Molecular Beam Epitaxy (GSMBE). Based on the patented Safe Delivery Source® (SDS®) technology used for ion implantation, SAGE™ gas sources provide numerous safety and operating benefits for MOCVD / GSMBE processing.

SAGE™ gas sources have been adopted for use in various MOCVD / GSMBE applications. High capacity SAGE™ gas sources reduce source changes that typically cause tool downtime and process re-qualification. Additionally, the inherent safety aspects of SAGE™ enable the delivery systems to be located next to the tool. This close proximity provides significant installation savings when compared to using a high-pressure source located in the gas pad.

SAGE™ gas sources consist of DOT approved cylinder packages that contain high purity adsorbent media. The hydride gas is adsorbed onto the media to a pressure of 650 Torr at room temperature. The large surface area of the adsorbent media allows the storage of highly toxic gas at sub-atmospheric pressure. The adsorbed gas is pulled from the SAGE™ source by using the RPM / Extractor SAGE™ Delivery System. Volumetric flows of 5 slpm are possible using SAGE™ gas sources. Release from a free standing SAGE™ cylinder will be diffusion limited and amount to < 10 sccm. This diffusion-limited release is the basis for the improved safety of the SAGE™ gas source.



SAGE™ Delivery System Schematic

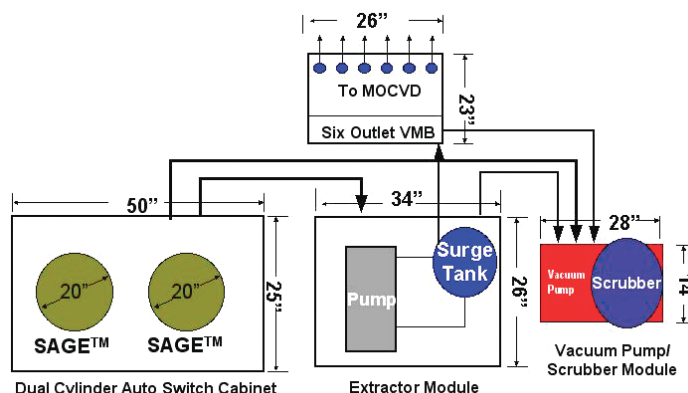

www.mathesontrigas.com

MATHESON
TRI·GAS®

Package Specifications

- Cylinder Pressure 650 Torr@ 21°C
(12.6 psia @ 70°F)
- Storage Temperature at or below 25°C (77°F)
- Tied Diaphragm Valve 316L Stainless Steel
Pneumatic Operation
- Outlet Connection UHIS SA-A Valve
(pin indexed)
- Shelf Life 24 months

Purity Analysis

Element	Trace Impurities	
	Arsine 99.9994% minimum	Phosphine 99.9996% minimum
Nitrogen (N ₂)	< 4.0 ppm	< 2.0 ppm
Carbon Monoxide (CO)	< 0.1 ppm	< 0.1 ppm
Methane (CH ₄)	< 0.5 ppm	< 1.0 ppm
Carbon Dioxide (CO ₂)	< 0.1 ppm	< 0.1 ppm
Ethane (C ₂ H ₆)	< 0.1 ppm	--
Germane (GeH ₄)	< 0.05 ppm	--
Oxygen (O ₂)	< 0.1 ppm	< 0.1 ppm
Water (H ₂ O)	< 0.2 ppm	< 1.0 ppm

Handling

D.O.T. Description	Arsine	Phosphine
Hazard Class	2.3, UN2188 Poison – Inhalation Hazard, Zone A	2.3, UN2199 Poison – Inhalation Hazard, Zone A
D.O.T. Shipping Labels	Poison Gas Flammable Gas	Poison Gas Flammable Gas
D.O.T. Guide Number	15	18
CAS Number	7784-42-7	7803-51-2

Cylinder Size	Cylinder Dimensions	Deliverable Capacity	
		Arsine @ 100 Torr	Phosphine @ 100 Torr
16 L	8.4" D x 30.5" H	4.8 lbs	1.9 lbs
49 L	9.3" D x 60" H	13.9 lbs	5.5 lbs
180 L	20" D x 56" H	51.8 lbs	20.4 lbs

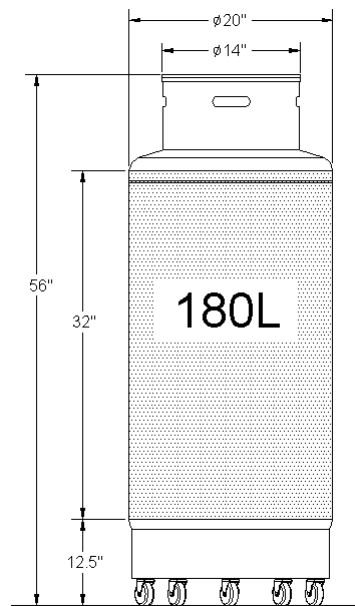
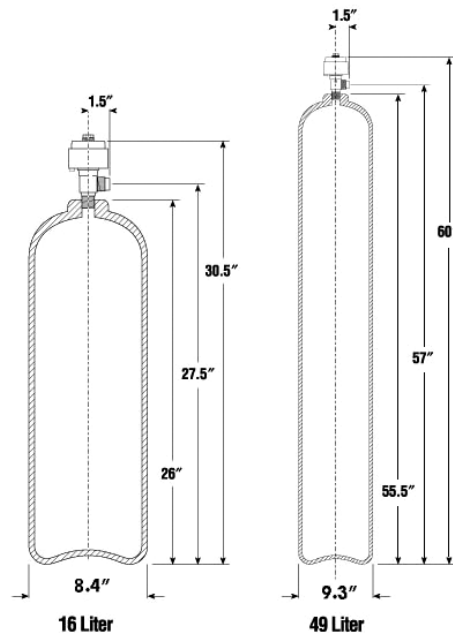

3700 Ivy Home Court
Richmond, VA 23233
Tel: (804) 290-0418
Email: III-V@matheson-trigas.com
www.mathesontrigas.com



SAGE is a trademark of ATMI
Printed in USA SAGE-01 6/03



...Everything Gas

**MATHESON
TRI-GAS®**