



Guide to Regulators



MATHESON

ask. . .The Gas Professionals™

Table of Contents

Section 1	_____
Regulator Primer	3
Section 2	_____
MATHESON's Product Line	7
Section 3	_____
Regulator Options and Accessories	13
Section 4	_____
Using Your Regulator	15
Section 5	_____
Performance Evaluation and Trouble Shooting	17
Section 6	_____
Glossary of Regulator Terms	19

Introduction

Choosing the right regulator for your application is critical – and often difficult. Product application, gas service, and required delivery pressure all influence regulator selection. At MATHESON, we understand gases, and we understand the importance of using the appropriate equipment for each gas. MATHESON's Guide to Regulators is a valuable tool that will help you pick the right product for your application, and get the most reliable results.



Section 1

Regulator Primer

How a Regulator Works

There are three basic operating components in most regulators: a loading mechanism, a sensing element, and a control element. These three components work together to accomplish pressure reduction.

The **Loading Mechanism** determines the setting of the regulator delivery pressure. Most regulators use a spring as the loading mechanism. When the regulator hand knob is turned, the spring is compressed. The force that is placed on the spring is communicated to the sensing element and the control element to achieve the outlet pressure.

The **Sensing Element** senses the force placed on the spring to set the delivery pressure. Most regulators use a diaphragm as the sensing element. The diaphragms may be constructed of elastomers or metal. The sensing element communicates this change in force to the control element.

The **Control Element** is a valve that actually accomplishes the reduction of inlet pressure to outlet pressure. When the regulator hand knob is turned, the spring (loading mechanism) is compressed. The spring displaces the diaphragm (sensing element). The diaphragm then pushes on the control element, causing it to move away from the regulator seat. The orifice becomes larger in order to provide the flow and pressure required.

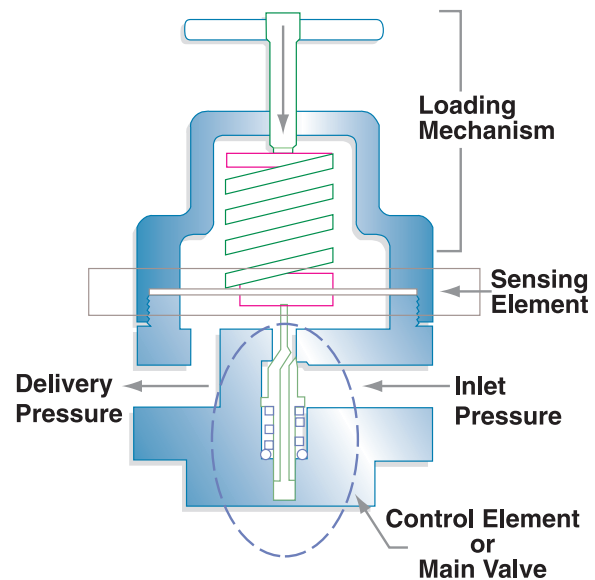

Features Determine Function

What makes a high purity regulator high purity?

High purity applications require equipment that will help maintain the purity of the system. High purity applications are sensitive to contamination from elements such as moisture, oxygen, and other gaseous vapors that may be present in ambient air. These contaminants enter the system when the regulator is removed from the cylinder during cylinder changeout, or they may enter through leaks or faulty seals.

The features of a regulator determine the type of service for which it can be used. A regulator intended for a high purity application has different features than a unit designed for general purpose use. Three main features determine the suitability of a regulator for high purity applications.

Body Type: Regulator bodies may be of forged or barstock construction. A forged body is formed by casting metal in a mold under pressure. A barstock body is made by machining out a solid piece of cold-drawn metal bar. Barstock bodies are used for high purity applications for the following reasons:

- **Reduced internal volumes:** Because barstock bodies are machined, it is possible to achieve a small internal cavity in the regulator body. The low internal volume makes purging the regulator easy, allowing for removal of contaminants like moisture and oxygen. It is difficult to achieve a low internal volume in the forging process; forged bodies have more “dead space” and tend to trap contaminants, and are more difficult to purge.
- **Tight grain structure of the metal:** The cold drawing process produces metal barstock with a very tight grain structure. This tight grain structure prevents the regulator’s internal surfaces from adsorbing moisture and contaminants, allowing them to be purged easily. The forging process produces a more porous grain structure; the internal surfaces of a forged body regulator tend to adsorb contaminants, which eventually find their way into the system.

- **Low Ra surface finish:** The machining process allows for very low Ra (roughness average) surface finishes on the barstock. The low Ra finish minimizes particle shedding, which contributes to contamination. It is difficult to achieve a low Ra finish in the forging process, making forged bodies susceptible to particle shedding and contamination.

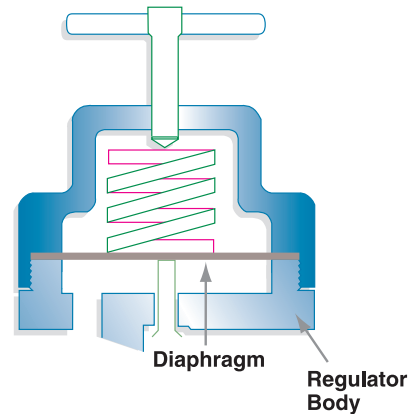

Diaphragm Material: Diaphragms may be constructed of elastomers (neoprene, Viton, etc.) or stainless steel. Stainless steel diaphragms are used in high purity regulators because they do not adsorb and release (or “offgas”) contaminants. When a regulator is removed from a cylinder, it is exposed to ambient air. An elastomeric diaphragm will adsorb moisture and other contaminants from the air. When the regulator is put back into service, the elastomeric diaphragm releases these contaminants, which eventually find their way into the system. A stainless steel diaphragm is unable to adsorb any contaminants, so it does not contribute to system contamination.



Barstock Construction



Forged Construction
(Note the larger size of the forged body)

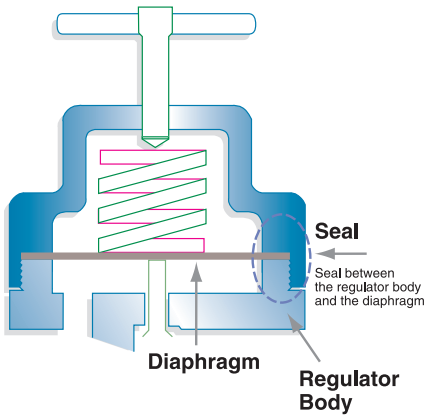

Type of Seals: The seal between the body of the regulator and the diaphragm is important in maintaining purity. A poor seal creates a leakage point through which contaminants may enter the system. A metal to metal seal (metal regulator body sealing to a metal diaphragm) is the most reliable, leak-free type of seal. An elastomeric diaphragm can degrade over time, compromising the integrity of this seal. Some regulator designs incorporate a stainless steel diaphragm that may be lined with an elastomer. Although the diaphragm is stainless steel, the seal is created between the regulator body and the elastomeric liner. Since the elastomeric liner may degrade, this seal is not as reliable as a metal to metal seal. Like an elastomeric diaphragm, the elastomeric liner may also adsorb and release contaminants into the system.

Features Influence Cost

A regulator designed for high purity applications is more costly than a regulator intended for general purpose use. Barstock bodies are more costly to produce than forged bodies due to the high amount of machining involved. Stainless steel is a more expensive diaphragm material than elastomers. It is important to remember that not all regulators are created equal when it comes to features.

Dual Stage Regulator

Dual Stage Regulators reduce the source pressure down to the desired delivery pressure in two steps. Each stage consists of a spring, diaphragm, and control valve. The first stage reduces the inlet pressure to about three times the maximum working pressure. The final pressure reduction occurs in the second stage.

The advantage of a dual stage regulator is its ability to deliver a constant pressure, even with a decrease in inlet pressure. For example, as a cylinder of gas is depleted, the cylinder pressure drops. Under these conditions, single stage regulators exhibit '**decaying inlet characteristic**'; the delivery pressure increases as a result of the decrease in inlet pressure. In a dual stage regulator, the second stage compensates for this increase, providing a constant delivery pressure regardless of inlet pressure. The dual stage regulator is recommended for applications such as gas supply to analytical instruments, where constant delivery pressure is critical.

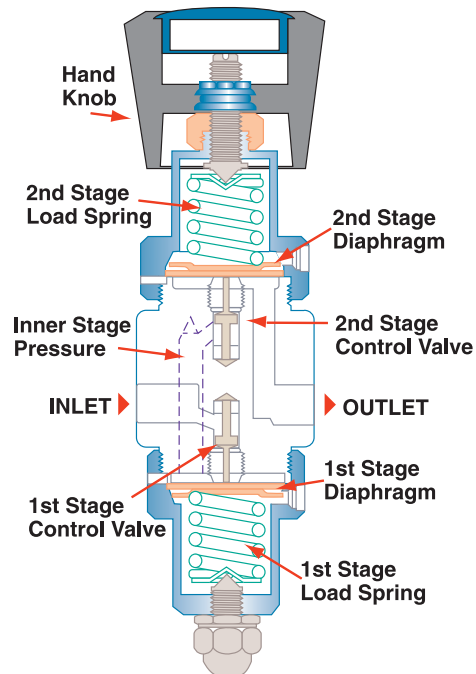

Single Stage Regulator

Single Stage Regulators accomplish the pressure reduction in a single step. Delivery pressure cannot be as tightly controlled as with a dual stage regulator. Single stage regulators should only be used where an operator can monitor and adjust pressure as needed, or where the regulator is supplied with a nearly constant source pressure.

Line Regulators are single stage regulators that are used to provide point-of-use pressure monitoring and control. For example, a lab may have gas cylinders located in a room on the first floor. The gas may be piped up to instruments located in a lab on the second floor. In this case, it is difficult to monitor the gas pressure directly at the instruments, since the regulators are located on the cylinders on the first floor. A line regulator may be installed near the instruments for convenience of monitoring the delivery pressure at the point of use. These regulators are installed directly into gas lines, and have a single delivery pressure gauge.

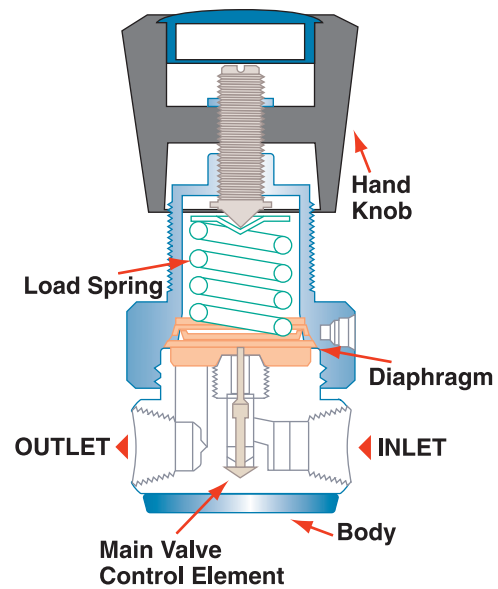

Section 2

MATHESON's Regulator Product

MATHESON's regulator products are grouped into three families: Basic Regulator Products, Specialty Regulator Products, and Transportable Cylinder Regulator Products.

Basic Regulator Products

General Purpose Regulators

- Used with gases that are less than 99.995% pure
- Used for applications where cost (not purity) is the main concern
- Economy and deluxe models

High Purity Regulators

- Used with gases that are 99.995% pure or higher purity
- Used for applications where maintaining system purity is the main concern
- Brass, aluminum, and stainless steel options
- Standard regulators or miniature regulators available

ULTRA-LINE® Ultra High Purity Regulators

- Used for applications where the highest possible purity is critical, such as semiconductor manufacturing
- Designed to minimize the risk of contamination

Basic Line Regulators

- Line regulators for general purpose, high purity, and ultra high purity applications

Specialty Regulator Products

The specialty regulators are intended for use with applications that require particular capabilities, such as low delivery pressures or high flow rates. There are general purpose and high purity options within the specialty regulator family.

High Pressure Regulators

- Delivery pressures up to 6,000 psig
- 10,000 psig inlet pressure available

Corrosive Service Regulators

- Used with acid forming halogens (HCl, HBr, etc.)

High Flow Regulators

- Flow rates up to 250 scfm

Low Pressure Regulators

- Low positive pressure and absolute pressure



Model 18
General Purpose Regulator



Model 3810A
High Purity Stainless Steel Regulator



Model 9460
ULTRA-LINE Regulator



Model 3430A
High Purity Line Regulator



Model 3210A
Deluxe Corrosive Service Regulator



Model 3396
Absolute Pressure Regulator



Model 6342A
Back Pressure Regulator



Model 3590
Low Dead Volume Regulator

Back Pressure Regulators

- Prevent system overpressure

Low Dead Volume Regulators

- Low internal volume designed for high sensitivity applications

Lecture Bottle Regulators

- Corrosive and non-corrosive service units for use with small lecture bottles

Specialty Line Regulators

- Line regulators for high flow and low delivery pressure applications



Model 3345
Nickel Plated Brass Preset Flow
Rate Regulator



Model 3359
Stainless Steel Preset Flow
Rate Regulator

MATHESON Portables™ Cylinder Regulator Products

These regulators are intended for use with MATHESON Portables™. Preset flow rate versions and a variable flow rate version are available, in a variety of materials.

Nickel Plated Brass Preset Flow Rate Regulators

- 30 psig delivery pressure, various CGA connections and preset flow rates

Stainless Steel Preset Flow Rate Regulators

- 30 psig delivery pressure, various CGA connections and preset flow rates

Brass Variable Flow Rate Regulators

- 50 psig delivery pressure, various CGA connections, 0-3 slpm adjustable flow rate

Aluminum Regulators

- Available with 1.5 slpm variable flow and rotameter, or with 0.5 slpm preset flow rate



Model 3347 Series
Brass Variable Flow Rate Regulator



Model RFM-0030-XX
Low Flow / Low Pressure Aluminum
Regulator

Regulator Selection Guide for GC Detectors



Model 3120A
High Purity Brass, Dual Stage Regulator



Model 3420A
High Purity Brass Line Regulator

Detector Type	Detection Level	Regulator
Flame Ionization Detector (FID)	All Levels	Model 3530A/3120A High Purity Brass Regulators, Model 3420 High Purity Brass Line Regulators
Thermal Conductivity Detector (TCD)	All Levels	
Nitrogen Phosphorus Detector (NPD)	All Levels	
Flame Photometric Detector (FPD)	All Levels	
Photoionization Detector (PID)	All Levels	
Helium Ionization Detector (HID)	All Levels	
Electrolytic Conductivity Detector (ELCD or Hall Detector)	Levels > 50 ppm	
Electron Capture Detector (ECD)	Levels > 50 ppm	



Model 3810A
High Purity Stainless Steel, Dual Stage
Regulator



Model 3200
High Purity Stainless Steel Regulator

Detector Type	Detection Level	Regulator
Electrolytic Conductivity Detector (ELCD or Hall Detector)	Levels < 50 ppm	Model 3510A/3810A High Purity Stainless Steel Regulators,
Electron Capture Detector (ECD)	Levels < 50 ppm	
Mass Selective Detector or Mass Spec (MSD or MS)	All Levels	Model 3200 High Purity Stainless Steel Regulators
Atomic Emission Detector (AED)	All Levels	

Product Line at a Glance

Basic Regulators

Regulator Family	Model Series	Gas Service	Stages	Max. Inlet (psig)	Outlet Range (psig) ¹	Design Features	Applications
General Purpose	18	Non-corrosive	1	3000	0-500	<ul style="list-style-type: none"> • Low cost forged brass bodies and neoprene diaphragms • Rugged construction • Large diaphragms provide good pressure control 	<ul style="list-style-type: none"> • Calibration of pressure gauges, rotameters, and mass flow controllers • Applications with high duty cycle/demanding operating conditions
	18A	Acetylene	1	400	0-15		
	81	Non-corrosive	2	3000	2-250		
	81-F (with flowmeter)	Non-corrosive	2	3000	2-50		
Economical High Purity Brass	1250	Non-corrosive	2	3000	2-250	<ul style="list-style-type: none"> • Low cost forged brass body with high purity stainless steel diaphragm • PTFE seals • Rugged construction • 320, 350, 580, 590 CGA's only 	<ul style="list-style-type: none"> • Supply of carrier gas or detector support gas for gas chromatography and other applications where low cost is the most important factor. The models 3120 (brass) and 3810 (stainless steel) should be used for the highest purity demanding applications as these models use barstock bodies and metal to metal seals.
High Purity Brass	3530A	Non-corrosive	1	3000	0-500	<ul style="list-style-type: none"> • Nickel plated brass barstock bodies • 316 stainless steel diaphragms • Metal to metal seals 	<ul style="list-style-type: none"> • Supply of carrier gas/detector support gas for a variety of gas chromatography applications (see chart on regulators for chromatography applications in 3530/3120 section) • Supply of calibration standards to on-line process analyzers, emission monitoring standards, etc.
	3120A	Non-corrosive	2	3000	0-500		
High Purity Stainless Steel	3510A	Semi- & non-corrosive	1	3000	0-500	<ul style="list-style-type: none"> • 316 stainless steel barstock bodies • 316 stainless steel diaphragms • Metal to metal seals • Tied diaphragm (3610) for safety 	<ul style="list-style-type: none"> • Supply of carrier gas/detector support gas for a variety of gas chromatography applications (see chart on regulators for gas chromatography applications in 3510/3810 section) • Supply of calibration standards to on-line process analyzers, emission monitoring standards, etc.
	3610A Tied Seat	Corrosive, toxic, and pyrophoric	1	3000	2-100		
	3810A	Semi- & non-corrosive	2	3000	0-500		
High Purity Miniature	3550 Brass	Non-corrosive	1	3000	0-100	<ul style="list-style-type: none"> • Brass or 316 stainless steel barstock bodies • 316 stainless steel diaphragms • Compact size 	<ul style="list-style-type: none"> • Applications requiring high purity gases and a compact regulator due to space limitations
	3570 Stainless Steel	Corrosive	1	3000	0-100		
	3850 Brass	Non-corrosive	2	3000	0-100		
	3870 Stainless Steel	Corrosive	2	3000	0-100		
ULTRA-LINE® Ultra High Purity	9300	Semiconductor	1	3000	0-100	<ul style="list-style-type: none"> • 316L stainless steel or Hastelloy C-22 internals • Autogeneous butt-welded connections 	<ul style="list-style-type: none"> • All semiconductor industry gas applications
	9360 Tied Seat	Semiconductor corrosive, toxic, and pyrophoric	1	3000	0-100		
	9460 Tied Seat	Semiconductor corrosive, toxic, and pyrophoric	2	3000	0-100		

Basic Regulators

Regulator Family	Model Series	Gas Service	Stages	Max. Inlet (psig)	Outlet Range (psig) ¹	Design Features	Applications
Basic Line Regulators	3470A General Purpose	Non-corrosive	1	350	2-200	<ul style="list-style-type: none"> Cast zinc (3470), brass barstock (3420), 316 stainless steel (3430), or 316L stainless steel (9330) bodies Neoprene (3470) or stainless steel diaphragms Tied diaphragm (9330) for safety 	<ul style="list-style-type: none"> 3470: Point of use regulation of inert gases 3420A & 3430A: Point of use regulation of high purity gases used in chromatography or other analytical applications (see chart on regulators for gas chromatography applications in 3420A/3430A sections) 9330: Point of use regulation in semiconductor applications
	3420A High Purity Brass	Non-corrosive	1	400	0-250		
	3430A High Purity Stainless Steel	Semi- & non-corrosive	1	400	0-250		
	9330 Ultra Line Tied Seat	Semiconductor, corrosive, toxic, or pyrophoric	1	3000	0-100		

¹ The outlet pressure ranges shown above include the minimum and maximum pressures available with respect to the entire model series. For delivery pressure ranges of individual regulator models, refer to appropriate catalog sections.

Specialty Regulators

Regulator Family	Model Series	Gas Service	Stages	Max. Inlet (psig)	Outlet Range (psig) ¹	Design Features	Applications
High Pressure	3030 Brass	Non-corrosive	1	3000	100-1500	<ul style="list-style-type: none"> Brass or stainless steel barstock bodies 316 stainless steel piston 	<ul style="list-style-type: none"> Applications requiring up to 6000 psig delivery pressure Manufacturing processes, charging of systems, purging 3060 series available relieving and non relieving
	3040 Brass	Non-corrosive	1	3000	100-2500		
	3060A Brass	Non-corrosive	1	7500	200-6000		
	3060SA Stainless Steel	Non-corrosive	1	10,000	200-6000		
	3060AR Brass	Non-corrosive	1	7500	200-6000		
3060SAR Stainless Steel	Non-corrosive	1	10,000	200-6000			
Standard Corrosive Service	3630A	Corrosives: HBr, HF, Cl ₂	1	3000	2-200	<ul style="list-style-type: none"> Stainless steel body Kel-F, and Hastelloy internals for corrosion resistance 	<ul style="list-style-type: none"> Use with acid forming halogen compounds (HBr, HF, Cl₂) Use with low vapor pressure gases
Deluxe Corrosive Service	3210A	Corrosives: HCl, HF, HBr, Cl ₂	1	3000	1-200	<ul style="list-style-type: none"> Monel construction and Monel/Kel-F internals for superior corrosion resistance 	<ul style="list-style-type: none"> Applications requiring extended regulator lifespan in severe conditions
Fluorine Corrosive Service	3225A	Corrosives: F ₂ and F ₂ mixtures	1	1000	1-50	<ul style="list-style-type: none"> Monel construction with bronze filled Teflon seat and Kel-F seals 	<ul style="list-style-type: none"> Use with fluorine and fluorine mixtures
High Flow	3200	Non-corrosive	1	3000	0-250	<ul style="list-style-type: none"> Brass (3240) or stainless steel (3200) barstock bodies 1/2" NPTF inlet and outlet ports 	<ul style="list-style-type: none"> Applications requiring a high flow rate, such as purging of large reactor or storage vessels
	3240	Non-corrosive	1	3000	0-250		

Product Line at a Glance (continued)

Speciality Regulators

Regulator Family	Model Series	Gas Service	Stages	Max. Inlet (psig)	Outlet Range (psig) ¹	Design Features	Applications
Low Pressure	81-2 General Purpose	Non-corrosive	2	3000	0.1-2	• Economical forged brass (81-2) or high purity brass barstock (3396) bodies	<ul style="list-style-type: none"> • 81-2: Applications requiring a reduction of full cylinder pressure down to a low working pressure, such as fuel supply to burners or purging low pressure environmental chambers • 3396: Applications requiring subatmospheric pressure control
	3396 Absolute Pressure	Non-corrosive	1	3000	28" Hg - 15 psig	• Economical Neoprene (81-2) or 316 stainless steel (3396) diaphragms	
Back Pressure	6342A	Corrosive & non-corrosive	1	100	0-100	<ul style="list-style-type: none"> • 316L stainless steel body • 316 stainless steel diaphragm 	<ul style="list-style-type: none"> • Used to relieve system overpressure, like a relief valve
Low Dead Volume	3590A	Non-corrosive	1	3000	2-100	<ul style="list-style-type: none"> • 7 cc internal volume minimizes contamination and adsorption • 316 stainless steel body & diaphragm 	<ul style="list-style-type: none"> • Use with mixtures containing trace quantities of reactive and/or adsorptive gases or vapors • 3590-TO specially cleaned for use with TO-14 calibration standards
	3590-TO	High purity TO-14 calibration standards	1	3000	2-100		
Lecture Bottle²	3320B	Non-corrosive	1	3000	2-60	<ul style="list-style-type: none"> • Forged brass (3230) or PVC (3330) bodies • Neoprene (3230) or Teflon (3330) diaphragm 	<ul style="list-style-type: none"> • Use with lecture bottles. 3330 designed for use with low pressure applications (1-6 psig); if higher pressures are required, use 3570 Series Mini Regulators
MicroMATE™ Preset Flow Rate	3345 Brass	Non-corrosive	1	240-1000 depending on model	30 psig (fixed)	<ul style="list-style-type: none"> • Brass or 316 stainless steel bodies • Fixed flow rate 0.3 slpm to 2.5 LPM • Push button (brass) or control knob (SS) on/off • Hose barb outlet • 3347: selectable flow rates from 0-3 slpm 	<ul style="list-style-type: none"> • Used with MicroMAT™-14, -58, -105, -221 cylinders for delivery of calibration gases at a fixed flow rate
	3359 Stainless Steel	Non-corrosive or Semi-corrosive	1	500 psig	30 psig (fixed)		
	3347A Brass Variable Flow	Non-corrosive	1	3000 psig	50 psig (fixed)		
Specialty Line Regulators	3450 High flow line regulator	Semi-corrosive: dichlorosilane, ammonia, amines	1	500	2-100	• High purity stainless steel body and diaphragm	• High purity, high flow applications (up to 730 SCFH)
	3491A Low delivery vacuum pressure line regulator	Non-corrosive	1	120	1 mm Hg - 1.8 psig	• Economical brass body and butyl rubber diaphragm	• Non-corrosive, absolute pressure applications
	3494 Absolute pressure line regulator	Corrosive/high purity gases	1	120	28" Hg - 15 psig	• High purity stainless steel body and diaphragm	• Corrosive/high purity absolute pressure applications
	3700 Low pressure line regulator	Non-corrosive	1	250	2" wc ³ - 10 psig	<ul style="list-style-type: none"> • Cast zinc body and natural rubber diaphragm • "Pancake" design 	• Non-corrosive, low inlet pressure/low delivery pressure applications

¹The outlet pressure ranges shown above include the minimum and maximum pressures available with respect to the entire model series. For delivery pressure ranges of individual regulator models, refer to appropriate catalog sections.

²Other regulators can be supplied with CGA 170/180 for use with lecture bottles. Consult Matheson technical support for more information.

³wc=water column

Helium Leak Testing

A helium leak test is used to determine the leak rate across the diaphragm or fittings on the regulator. The leak rate value should be as low as possible to prevent contamination by ambient air or escape of hazardous gases.

A complete helium leak test involves monitoring the inboard leakage and the outboard leakage of a regulator. This testing is available for a fee. Inboard leak testing involves drawing an internal vacuum on the regulator, and surrounding it with helium. The helium leak rate from the outside of the regulator to the inside of the regulator is then monitored. Outboard leak testing is performed by pressurizing the regulator with helium and analyzing the surrounding space for the presence of helium. Upon completion of the tests, a certificate is written and forwarded with the item to the customer.

Flash Arrestors

Flash arrestors are safety devices that shut off the gas flow if a flashback occurs in a system. A flashback is the combustion of a flammable mixture within the tubing or piping of a gas transfer system. If the flashback travels back through the piping and reaches the regulator, the regulator becomes a small bomb. If it reaches the gas cylinder, the cylinder becomes a large bomb.



Model 6104A
Flash Arrestor

As the flashback occurs, it is preceded by a shock wave. The flash arrestor senses the shock wave and closes a valve that shuts off the gas flow. The flame is detoured through three feet of spiral tubing in the flash arrestor, where it is extinguished. The flash arrestor also incorporates a reverse flow blocking mechanism that effectively prevents accidental mixing of gases in the regulator. Flash arrestors are available in brass (Model 6103) and stainless steel (Model 6104), and may be reset and reused up to three times after a flashback has occurred.

Purge Assemblies

A purge assembly is recommended for use with toxic, corrosive, or flammable gases. The assemblies are available in a cross purge configuration (Models 4774 and 4775) and a tee purge configuration (Models 4753-4756). The tee purge and the cross purge help to ensure safety when working with hazardous gases. The cross purge also protects the system from atmospheric contamination. The tee purge is used for general purpose corrosive applications; the cross purge is used for high purity applications where preventing contamination is critical.

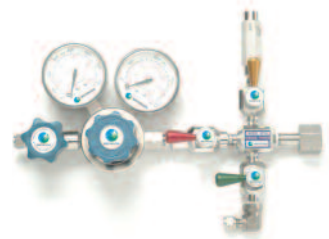

Model 4774
Cross Purge Assembly, shown
with a Model 3210 Deluxe
Corrosive Service Regulator

Safety: When a regulator is removed from a cylinder of toxic or flammable gas, some gas is released into the work atmosphere. Some materials (such as silane) will spontaneously ignite when exposed to air. A purge assembly is used with an inert gas to flush all hazardous gases from the regulator, eliminating their release when the regulator is removed from the cylinder. Corrosive gases like hydrogen chloride present severe corrosion problems when they are exposed to moisture. The cross purge's valving configuration allows the regulator to be closed off completely from the atmosphere before removing it from the cylinder. Closing the valves prevents atmospheric moisture from contacting the gas, minimizing corrosion.

Purity: Atmospheric contaminants like moisture and oxygen cannot be tolerated in a high purity system. When a regulator is removed from a cylinder, atmospheric oxygen and moisture enter the regulator. When the regulator is put back into service, these contaminants enter the system. As mentioned above, the cross purge's valving configuration allows the regulator to be completely isolated from the atmosphere, preventing contaminants from entering the system.



Single Station Manifold

Single Station Manifolds

A single station manifold is used to mount a regulator to a wall. These units consist of a stainless steel bracket and a stainless steel flex hose with a CGA connection and integral check valve. Wall mounting the regulator eliminates the need to handle the regulator during cylinder changeout, minimizing the risk of it being improperly reinstalled. The check valve in the CGA connection prevents the release of gas when the cylinder is changed, and prevents ambient air from entering the system. The Model 53 has brass end connections, and the Model 54 has stainless steel end connections.



*Model 6290
Excess Flow Valve*

Excess Flow Valves

The excess flow valve (Model 6290 Series) is designed to shut down the gas supply in case of abnormal flow conditions caused by rupture, fire, or malfunctioning valves. The valve will automatically detect excess flow when the event occurs and will shut down the supply flow immediately so that the remaining contents of the cylinder(s) does not empty into the work or storage area. This feature is critical with toxic, poisonous, or flammable gases, but can also be important when dealing with inert gases in small, poorly ventilated areas where asphyxiation is a potential hazard.

Section 4

Using Your Regulator

Installing the Regulator

Regulators are equipped with CGA (Compressed Gas Association) fittings for connection to cylinders. Each CGA connection has a numerical designation, and a listing of gases with which it may be used. The CGA prevents a regulator from being used on incompatible

gases. For example, the CGA connection designated for use with oxygen (CGA 540) cannot be used on a cylinder of hydrogen. The table on page 18 lists common gases and their corresponding CGA connections.

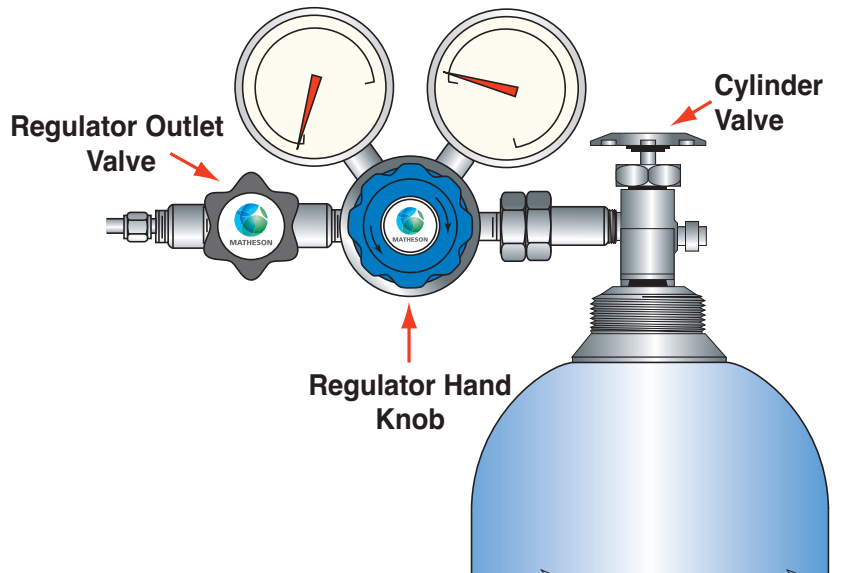

Connecting the Regulator to the Cylinder and Setting the Delivery Pressure

1. Close the regulator by rotating the hand knob in a counterclockwise direction.
2. Close the regulator outlet valve by rotating the valve knob in a clockwise direction.
3. Connect the regulator to the cylinder. The regulator should be attached to the cylinder without forcing the threads. If the inlet of the regulator does not fit the cylinder outlet, it is likely that the regulator is not intended for the gas service.
4. Slowly open the gas cylinder valve. Check the inlet pressure gauge to ensure that it registers the expected value. Low cylinder pressure may indicate a leaking valve, which can be a serious safety issue.
5. Check all high-pressure connections for leaks using an approved soap solution or leak detection device.
6. Open the cylinder valve completely.
7. Adjust the regulator hand knob to raise the delivery pressure to the desired value. Do not exceed the maximum delivery pressure indicated by the model number label on the regulator.
8. Open the outlet valve on the regulator to establish gas flow to the system. This valve is used to control the gas flow. The regulator itself should not be used as a flow controller by adjusting the pressure to obtain different flow rates. This practice defeats the purpose of the pressure regulator, and may result in a pressure setting that is in excess of the design pressure of the system.
9. After flow is established, the set delivery pressure may decrease slightly. Check to see that the delivery pressure is as desired and make any necessary adjustments.

Removing the Regulator from the Cylinder

For temporary shutdown (less than 30-minute duration), simply close the regulator outlet valve.

For extended shutdown (beyond 30-minute duration) follow these steps:

1. Shut off the gas cylinder valve completely.
2. Shut down any additional gas supplies that may be supplying gas to the system.
3. Open the regulator and the outlet valve to drain the contents of the regulator through the system in use. Both regulator gauges should descend to zero.
4. When using a toxic or other hazardous gas, purge the regulator and system with an inert gas (see instructions on Purging the Regulator, below).
5. Close the regulator by rotating the hand knob counterclockwise. Close the outlet valve by rotating the valve knob clockwise.

6. Disconnect the regulator from the system or downstream equipment.
7. Disassemble the regulator from the cylinder by slowly loosening the cylinder connection. Listen for gas seepage. If leakage is evident, re-tighten the cylinder connection immediately, and check the cylinder valve for proper closure. If leakage occurs when the cylinder valve is closed, and the regulator has been drained of all gases, contact the gas supplier immediately.
8. Replace the plug into the cylinder valve outlet (where applicable). Replace the cap on the cylinder over the valve. Remove the cylinder from the work place and put the cylinder into a safe storage area. Replace the empty cylinder with a new one and re-install the regulator.

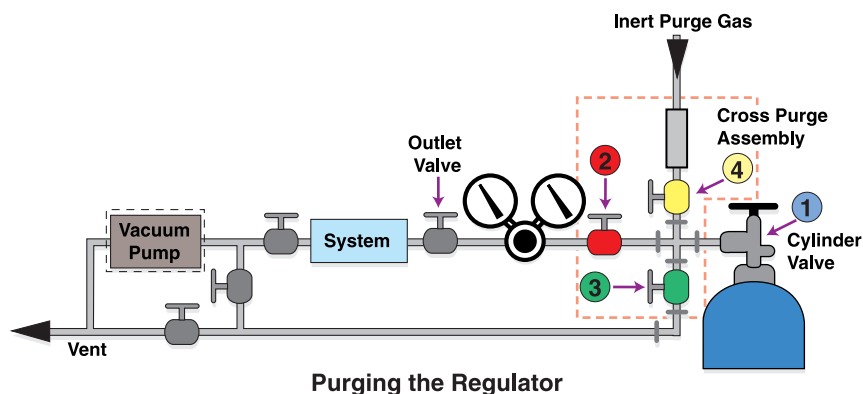

Purging the Regulator Using a Cross Purge Assembly

1. Close cylinder valve 1 and valve 2.
2. Open valves 3 and 4 allowing the inert purge gas to flush the Cross Purge Assembly.
3. Alternately close and open valve 3 a few times to dilute any gas trapped in the Cross Purge Assembly by pressurizing and venting.
4. Close valve 3. Close valve 4 until barely open. This will ensure a continuous small flow of inert purge gas during the time the inlet connection is open to the atmosphere.
5. Disconnect the regulator from the empty cylinder and reconnect it to the replacement cylinder.
6. Close valve 4.
7. Open valve 3. Evacuate the assembly, if possible, then re-close valve 3. If this is not possible, steps 2 and 3 should be repeated.
8. Open the cylinder valve 1 long enough to fill the Cross Purge Assembly with cylinder gas, and then re-close.
9. Repeat steps 7 and 8 once more if evacuation facilities are available; four more times if venting to atmosphere. At 225 psig cylinder pressure, this practice will dilute the purge gas to below 1 ppm.
10. Check to ensure that valves 3 and 4 are securely closed; the valve handles should be horizontal. Valve 2 may be opened. The handle will indicate the direction of the flow.

Several things are evaluated to determine a regulator's performance.

- **Pressure regulation as a function of flow:** All regulators experience some delivery pressure drop with increased flow rate. The smaller the drop as flow is increased, the better the performance.
- **Pressure regulation as a function of inlet pressure:** As a cylinder's contents are depleted and the inlet pressure drops, the regulator delivery pressure may either rise or fall depending on the regulator design. In both cases, this is known as regulator "droop." Two stage regulators generally provide better regulation under these circumstances.
- **"Lockup" of a regulator:** Lockup is the difference in pressure between a flowing and a non-flowing condition. If a regulator has its delivery pressure set while gas is flowing, and flow is suddenly stopped, a small rise in delivery pressure (lockup) will occur before the regulator's valve closes fully. The lower the lockup, the better the performance.
- **Seat leakage of the regulator:** Seat leakage is the tendency of gas to leak across the regulator seat, when the regulator outlet valve knob is fully closed (turned counterclockwise) and a high pressure source exists on the inlet side. A low leakage value is preferred.
- **Leakage rate across the diaphragm or fittings on the regulator:** This leakage value is normally measured using helium gas and a mass spectrometer or other type of helium leak detector. Regulators for specialty gas service may have published values of typical leakage rates either inboard (from the atmosphere into the regulator) or outboard (from the inside of the regulator to the atmosphere). For safety, it is important that this leak rate value be as low as possible in order to prevent possible contamination by ambient air and moisture or escape of hazardous gases.

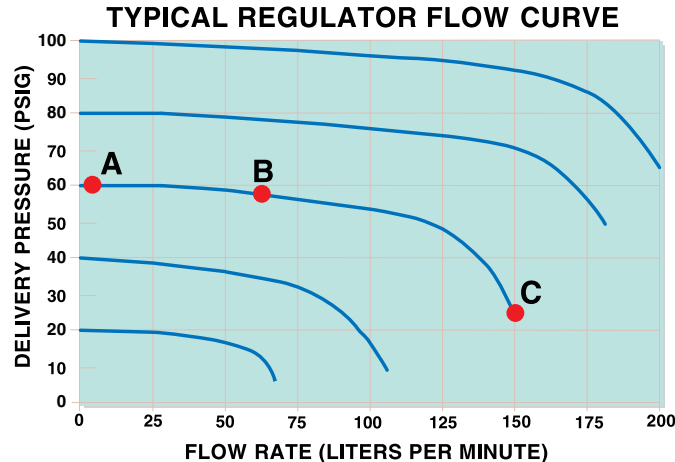

Reading Flow Curves

The flow properties of a regulator are illustrated by the flow curve. The vertical axis indicates the delivery pressure at which the regulator is set, and the horizontal axis indicates the gas flow that the regulator passes. The curves are made by setting the delivery pressure while there is no gas flow, and then slowly opening the outlet valve downstream while measuring both the flow and the delivery pressure. Typically, as flow increases, delivery pressure drops. The portion of the curve to the far left is flat; in this range, the regulator demonstrates a stable pressure regulation although the flow is changing.

For example, increasing the flow from point "A" to point "B" results in a slight decrease in pressure. The portion of the curve to the right shows a rapid drop in pressure with increasing flow rate, indicating that the regulator valve seat is almost wide open. If flow is increased from point "B" to point "C", there is a large drop in pressure that is typical for all regulators.

Compressed Gas Association Valve Outlet Listing

Gas	CGA Valve Outlet & Conn. No. CGA/UHP CGA
Acetylene	510
Air, Breathing	346
Air, Industrial	590*
Allene	510**
Ammonia, Anhydrous	705**
Ammonia, Electronic	660/720
Argon	580*/718
Argon-3500 psig	680***
Argon-6000 psig	677
Arsine	350/632
Boron Trichloride	660**/634
Boron Trifluoride	330**/642
1,3-Butadiene	510*
Butane	510*
Butenes	510*
Carbon Dioxide	320*/716
Carbon Monoxide	350*/724
Carbonyl Fluoride	660
Carbonyl Sulfide	330**
Chlorine	660**/728
Cyanogen	660
Cyanogen Chloride	660
Cyclopropane	510*
Deuterium	350*
Dichlorosilane	678/636
Dimethylamine	705**
Dimethyl Ether	510*
2,2-Dimethylpropane	510
Ethane	350*
Ethyl Chloride	300*
Ethylene	350*
Ethylene Oxide	510**
Fluorine	679
Germane	350/632
Halocarbon 12 (Dichlorodifluoromethane)	660*/716
Halocarbon 13 (Chlorotrifluoromethane)	660/716
Halocarbon 13B1 (Bromotrifluoromethane)	660
Halocarbon 14 (Tetrafluoromethane)	320*/716
Halocarbon 22 (Chlorodifluoromethane)	660*
Halocarbon 23 (Fluoroform)	660/716
Halocarbon 114 (2,2-Dichlorotetrafluoroethane)	660*
Halocarbon 115 (Chloropentafluoroethane)	660*/716
Halocarbon 116 (Hexafluoroethane)	660
Halocarbon 142B (1-Chloro-1,1-difluoroethane)	510
Halocarbon 1113 (Chlorotrifluoroethylene)	510
Helium-3500 psig	680***
Helium	580*/718
Hexafluoropropylene	660*

Gas	CGA Valve Outlet & Conn. No. CGA/UHP CGA
Hydrogen	350*/724
Hydrogen-3500 psig	695***
Hydrogen Bromide	330**/634
Hydrogen Chloride	330**/634
Hydrogen Fluoride	660**/638
Hydrogen Iodide	330**
Hydrogen Selenide	350
Hydrogen Sulfide	330**/722
Isobutane	510*
Isobutylene	510*
Krypton	580/718
"Manufactured Gas B"	350
Methane	350*
Methyl Bromide	330
3-Methyl-1-butene	510
Methyl Chloride	660*/510
Methyl Fluoride	350/724
Methyl Mercaptan	330**
Monomethylamine	705**
Neon	580*/718
Nitric Oxide	660/712/728
Nitrogen	580*/718
Nitrogen-3500 psig	680***
Nitrogen-6000 psig	677
Nitrogen Dioxide	660
Nitrogen Trioxide	660
Nitrous Oxide	326*/712
Octafluorocyclobutane	660*/716
Oxygen	540*/714
Oxygen Mixtures Over 23%	296
Perfluoropropane	660*/716
Phosgene	660
Phosphine	350/632
Phosphorus Pentafluoride	330/642/660**
Propane	510*
Propylene	510*/791/810
Silane (High Pressure)	350/632
Silicon Tetrafluoride	330**/642
Sulfur Dioxide	660**
Sulfur Hexafluoride	590*/716
Sulfur Tetrafluoride	330**
Trimethylamine	705**
Vinyl Bromide	510
Vinyl Methyl Ether	510
Xenon	580**/718

*Lecture bottles use CGA No. 170
**Lecture bottles use CGA No. 180
***For information on CGA 680 and 695 connections contact your nearest MATHESON office.

The following terms may be encountered when dealing with regulators.

Burst Pressure –	A design test pressure which determines the ultimate structural strength of a regulator or valve. Permanent deformation and leakage are permitted, but parts must remain assembled (no sudden ruptures).
Captured Venting –	A feature incorporated in a self-venting pressure reducing regulator which provides an additional port to permit the piping away of the expelled gas from the regulator's vent valve.
Control Element –	One of the three basic elements of a pressure regulator. It acts to reduce a high inlet pressure to a lower working or delivery pressure. The control element is sometimes called a main valve, valve stem, or poppet.
Cv –	See "Flow Capacity"
Decaying Inlet Characteristic –	The effect of the set pressure of a regulator as a result of an inlet pressure change; normally an increase in outlet pressure due to a decrease in inlet pressure.
Diaphragm –	A type of sensing element used in a regulator. Common diaphragm materials are Buna-N, Viton, Ethylene Propylene, 316 Stainless Steel, and Elgiloy.
Droop –	The outlet pressure change (or offset) from the "set pressure" which occurs as flow rate increases.
Flow Capacity (Cv) –	The maximum flow capability of a regulator or valve established at a specific set of conditions. The standard coefficient is the term 'Cv', which is defined as the flow of one GPM of water at one PSI pressure drop. The term Cv for gaseous service is dependent on the ratio of inlet to outlet pressure and must be determined by the use of the appropriate formulae.
Inlet Pressure (P1) –	The pressure of the gas at the supply connection of a regulator or valve. Typical units of measure are psig, bar, or pascal.
Leakage, Inboard –	Leakage through an external joint or seal where the direction of flow is from the outside into the regulator or valve. The leakage rate is measured in atm cc/sec He(lium).
Leakage, Outboard –	Leakage through an external joint or seal where the direction of flow is from the inside of the regulator or valve to the outside. The leakage rate is measured in atm cc/sec He(lium), and the pressure inside the regulator should be stated.
Load Element –	One of the three basic elements of a pressure reducing regulator (usually a spring). It provides the means by which the operator can set the force that determines the outlet pressure of the regulator.
Lockup –	The outlet pressure increase that occurs above the "set pressure" as the flow is decreased to zero.
Outlet Pressure (P2) –	The pressure of the gas from the discharge connection of a regulator or valve.
Sensing Element –	One of the three basic elements of a pressure reducing regulator, typically a diaphragm. It senses the changes in the outlet pressure, permitting the regulator to react in an attempt to return to the original "set pressure" by increasing or decreasing pressure.
Set Pressure –	The desired operational outlet pressure for a regulator, normally stated at NO FLOW conditions.

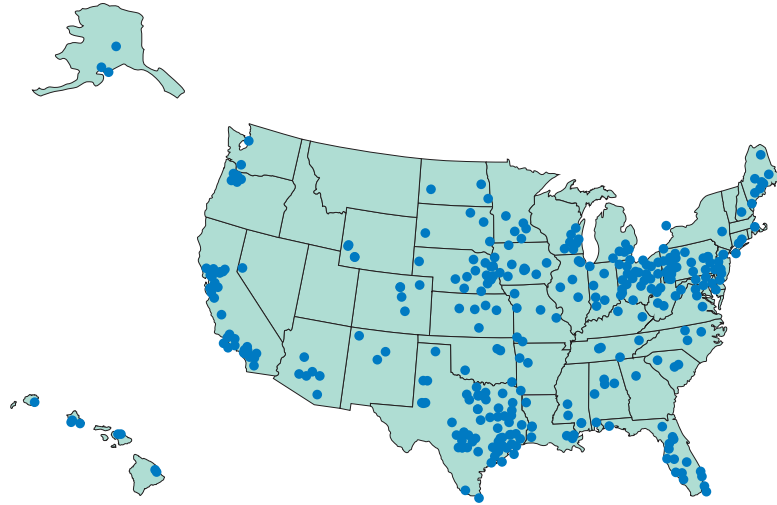

MATHESON

ask . . The Gas Professionals™

www.mathesongas.com

877-684-4427

Copyright 2019 Matheson Tri-Gas, Inc. All Rights Reserved.

All contents of this document are subject to change without notice and do not represent a commitment on the part of Matheson Tri-Gas, Inc. Every effort is made to ensure the accuracy of this information. However, due to differences in actual and ongoing operational processes and product improvements and revisions, Matheson Tri-Gas, Inc. cannot guarantee the accuracy of this material, nor can it accept responsibility for errors or omissions. This document is intended to serve as a general orientation and cannot be relied upon for a specific operation. No warranties of any nature are extended by the information contained in these copyrighted materials.

All names, products, and services mentioned herein are the trademarks or registered trademarks of their respective organizations and are the sole property of their respective owners. Matheson and the Matheson logo are registered trademarks of Matheson Tri-Gas, Inc.