

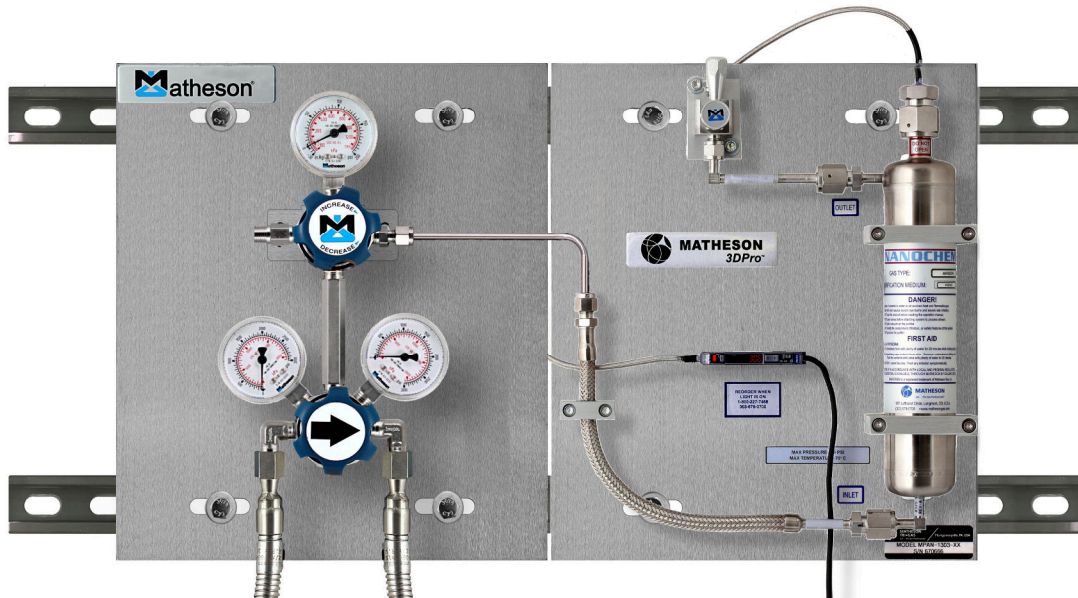

**MATHESON**  
3DPro™

## Point of Use / Add-on Purifier Panel System

### Installation, Operation, and Maintenance Instructions



INT-0349-XX Rev B

MATHESON  
166 Keystone Drive  
Montgomeryville, PA 18936

Telephone: 215-641-2700  
Fax: 215-641-2714

**TABLE OF CONTENTS**

<u>SECTION</u>	<u>PAGE NUMBER</u>
<b>LIMITED WARRANTY .....</b>	<b>3</b>
<b>USER RESPONSIBILITY .....</b>	<b>4</b>
<b>SAFETY PRECAUTIONS .....</b>	<b>4</b>
<b>SPECIFICATIONS.....</b>	<b>6</b>
<b>1.0 SWITCHOVER DESCRIPTION .....</b>	<b>7</b>
<b>2.0 PURIFIER PANEL DESCRIPTION .....</b>	<b>8</b>
<b>3.0 SWITCHOVER / PURIFIER PANEL INSTALLATION.....</b>	<b>9</b>
<b>4.0 PURIFIER INSTALLATION &amp; CONDITIONING.....</b>	<b>10</b>
<b>5.0 PROCESS CYLINDER INSTALLATION INSTRUCTIONS .....</b>	<b>13</b>
<b>6.0 OPERATING INSTRUCTIONS – SWITCHOVER.....</b>	<b>14</b>
<b>7.0 CYLINDER CHANGEOUT.....</b>	<b>16</b>
<b>8.0 SHUTDOWN PROCEDURES.....</b>	<b>18</b>
<b>9.0 TROUBLESHOOTING.....</b>	<b>19</b>
<b>APPENDIX - FITTINGS .....</b>	<b>20</b>

## LIMITED WARRANTY

This equipment is sold by Matheson Tri-Gas (MATHESON) under the warranties set forth in the following paragraphs. Such warranties are extended only with respect to the purchase of this equipment directly from MATHESON or MATHESON'S Authorized Agent as new merchandise and are extended to the first Buyer thereof other for than the purpose of resale.

For a period of one year from date of original delivery to Buyer or to Buyer's order, this equipment, is warranted to be free from functional defects in materials and workmanship and to conform to the description of this equipment contained in this manual and any accompanying labels and/or inserts, provided that this equipment is properly operated under the conditions of normal use and that regular and periodic maintenance and service is performed or replacements are made in accordance with the instructions provided. Expendable parts of this equipment are similarly warranted to be free from functional defects in materials and workmanship and to conform to the description of this equipment contained in this manual and any accompanying labels and/or inserts. The foregoing warranties shall not apply if the equipment has been repaired other than by MATHESON or a service facility designated by MATHESON, or if this equipment has not been operated and maintained in accordance with written instructions provided by MATHESON, or has been altered by anyone other than MATHESON, or if the equipment has been subject to abuse, misuse, negligence or accident.

MATHESON'S sole and exclusive obligation and the Buyer's sole and exclusive remedy under the above warranties is limited to repairing or replacing, free of charge, at MATHESON'S sole discretion, the equipment or part which is telephonically reported to be a problem to the local MATHESON Branch Location, and which if so advised, is returned with a written statement of the observed deficiency, not later than seven days after the expiration of the applicable warranty, to the MATHESON Gas Equipment Technology Center during normal business hours, transportation charges prepaid, and which, upon examination, is found to comply with the above warranties. The Buyer shall pay for return trip transportation charges for the equipment or part.

MATHESON SHALL NOT BE OTHERWISE LIABLE FOR ANY DAMAGES INCLUDING BUT NOT LIMITED TO INCIDENTAL DAMAGES, CONSEQUENTIAL DAMAGES, OR SPECIAL DAMAGES, WHETHER SUCH DAMAGES RESULT FROM NEGLIGENCE, BREACH OF WARRANTY OR OTHERWISE.

THERE IS NO EXPRESS OR IMPLIED WARRANTIES THAT EXTEND BEYOND THE WARRANTIES HEREINABOVE SET FORTH. MATHESON MAKES NO WARRANTY OF MERCHANTABILITY OR FITNESS FOR A PARTICULAR PURPOSE WITH RESPECT TO THE EQUIPMENT OR PARTS THEREOF.

## USER RESPONSIBILITY

This equipment will perform in conformity with the description thereof contained in this manual and accompanying labels and/or inserts when installed, operated, maintained and repaired in accordance with the instructions provided. This equipment must be checked periodically, with the frequency of such inspections depending upon the scope of use. Damaged, worn or contaminated equipment should not be used. Parts that are broken, missing, plainly worn, distorted or contaminated should be replaced immediately. Should such repair or replacement become necessary, MATHESON recommends that a telephonic or written request for service advice be made to the MATHESON Equipment Engineering Group in Montgomeryville Pennsylvania or to the nearest MATHESON Branch location.

This equipment or any of its parts should not be altered without the prior written approval of MATHESON Equipment Engineering Group. The user of this equipment shall have the sole responsibility for any malfunction, which results from improper use, faulty maintenance, damage, improper repair or alteration by anyone other than MATHESON or a service facility designated by MATHESON. Further, the ultimate user of the equipment is responsible for the training and safe operation of the equipment by personnel in his/her employ.

## SAFETY PRECAUTIONS

1. Many Specialty Gases are hazardous in nature. It is important that the user of the equipment carefully review the hazards associated with the gas to be used with the switchover system.  
**BEFORE INSTALLING THE SWITCHOVER SYSTEM WITH ANY CYLINDER OF COMPRESSED OR LIQUIFIED GAS, REFER TO THE MSDS THAT WAS SHIPPED WITH THE GAS, OR ON FILE IN YOUR FACILITY, AS TO THE SPECIFIC HAZARDS ASSOCIATED WITH THE GAS TO BE USED. ALSO, REFER TO ALL APPLICABLE INSERTS CONTAINED WITH THE EQUIPMENT FOR ADDITIONAL PRECAUTIONS AND OPERATING INSTRUCTIONS.**
2. Before using any switchover system on toxic, flammable or other type of hazardous gas, test the leak integrity of the switchover system using an inert gas. The SwitchPro™ Automatic Switchover System is not recommended for use with acetylene, corrosive or pyrophoric gases.
3. Make certain that the switchover system purchased is suitable for the application intended. All equipment supplied by MATHESON has a model number, and a pressure limitation label and/or stamping. Carefully review this information to establish the switchover system fit for service in the desired application.
4. Make certain that the equipment purchased or delivered to the ultimate end user conforms to the specifications of the user. The user is responsible for selecting equipment compatible with gases that are to be used, physical parameters of operation and performance and normal material compatibilities. Selection information can be found in MATHESON Catalogs, MATHESON Tech Briefs and in the MATHESON Gas Data Book. In addition, any MATHESON representative would be pleased to aid in the selection of specific equipment.

5. Before installation of the switchover system for use with cylinders of compressed or liquified gas, carefully inspect the switchover system for visible signs of damage or contamination. Close attention should involve visual inspection of all exposed and connecting threads for visible signs of wear and abuse. Also examine the switchover system for any loose parts outside of those that must swivel for connection to the gas cylinder or outlet lines. Also examine the switchover system for signs of contamination with dirt, grease or any other foreign material. Close attention should be given to the external appearance and the view of the switchover system from the inlet and the outlet. If any foreign materials are present and cannot be removed from the switchover system easily with a cloth, or if the threads on any components of the switchover system appear to be abused as indicated above, or any of the components appear to be loose, return the switchover system immediately for service.
6. Before installation of the SwitchPro™ Automatic Switchover System onto the cylinder of compressed or liquified gas, move the cylinder(s) to the work location and secure the cylinder before removing the cylinder valve cap. Check the cylinder valve as in step 5 for possible contamination and defective or loose parts. If for any reason the cylinder appears to be faulty as noted here, return the cylinder cap to the top of the cylinder, tighten down and remove the cylinder from the work area and call the supplier of the cylinder for immediate pick-up.
7. When using any hazardous gas, the cylinder of the gas should be placed under an exhaust hood or be placed in a suitable safety enclosure.
8. Before installation of the switchover system for use with cylinders of compressed or liquified gas, make certain that the CGA connection on the cylinder matches the CGA connection attached to the pigtail. CGA connections are fitted to the pigtails to limit the services in which the switchover system can be used. **THE USE OF ADAPTORS OR ALTERATIONS TO THE SWITCHOVER SYSTEM TO CHANGE SERVICES CAN BE EXTREMELY DANGEROUS AND SHOULD NOT BE ATTEMPTED.** If a conversion of a product is required, consult MATHESON before attempting.

## SWITCHOVER PANEL

### Specifications

Maximum Supply Pressure	3000 psig maximum or rating of CGA inlet connection
Switchover Pressure	180-220 psig (typical)
Maximum Flow Rate	3 SCFM-N <sub>2</sub>
Delivery Pressure:	150 psig (optional 100 psig or 30 psig)

### Material

Regulators	316 stainless steel (optional plated brass barstock)
Gauges	316 stainless steel (optional plated brass barstock)
Valves (if equipped)	316 stainless steel (optional plated brass barstock)
Relief Valve	316 stainless steel (optional brass barstock)
Flex Hoses	316 stainless steel
Fittings	316 stainless steel (optional brass barstock)
Cylinder Connections	316 stainless steel (optional plated brass barstock)

## NANOCHEM PURIFIER PANEL

### Specifications

Maximum Supply Pressure	150 psig maximum rating
Maximum Flow Rate	53 SCFH-N <sub>2</sub> (25 SLPM-N <sub>2</sub> )
Purification	Oxygen and moisture
Purifier Life Expectancy:	1 year, dependent on inlet gas purity, flow, duty cycle

### **Typical Performance**

Impurities are typically removed to the detection limits of state-of-the-art analytical techniques:

Impurity	Efficiency (ppb)	Challenge (ppm)
H <sub>2</sub> O in Ar	<0.3 (LDL*)	35
O <sub>2</sub> in Ar	<0.14 (LDL)	1
CO <sub>2</sub> in He	< 11 (LDL)	500

\*Lower Detectable Limit

### Materials

Purifier	Stainless steel, glass
Media	Nanochem® IN2GO™
Valves	316 stainless steel
Flex Hose	316 stainless steel
Tubing	316 stainless steel
Fittings	316 stainless steel

## 1.0 SWITCHOVER DESCRIPTION

The SwitchPro™ Automatic Switchover System provides primary regulation and switchover capability for an uninterruptible supply. The SwitchPro™ Automatic Switchover System is designed for high purity use and relatively moderate flow rates of gas. The switchover may be used with one or two cylinders on each side or with a multi-cylinder manifold bank on each side.

The SwitchPro™ Automatic Switchover System will switch over from one bank of cylinders to the opposite bank of cylinders automatically upon depletion of gas in the original Primary side of the system. However, some delivery pressure deviation (decrease after switchover) from the set point will occur after the switch from the Primary to the Reserve bank. The use of a secondary line regulator downstream eliminates this delivery pressure deviation. While these units are designed to provide a continuous supply of gas to a common outlet, the ability to remotely monitor when one side of the switchover has been exhausted may be necessary to determine when to replenish that side. Optional features for monitoring the supply pressures are available and include indicating pressure switches along with a PM-24 pressure monitor.

The SwitchPro™ Automatic Switchover System can be configured with many available options. When complete purging is required, optional high pressure vent (HPV) and high pressure isolation (HPI) valves can be ordered as options to the switchover system. A low pressure isolation (LPI) valve provides system isolation from the down stream process. Three foot long flexible hoses are standard but can be substituted by six foot long hoses if the user wants flexibility when using cumbersome dewars or six/twelve packs of cylinders. Various outlet fittings are also available.

For additional information contact your local MATHESON Sales Representative.

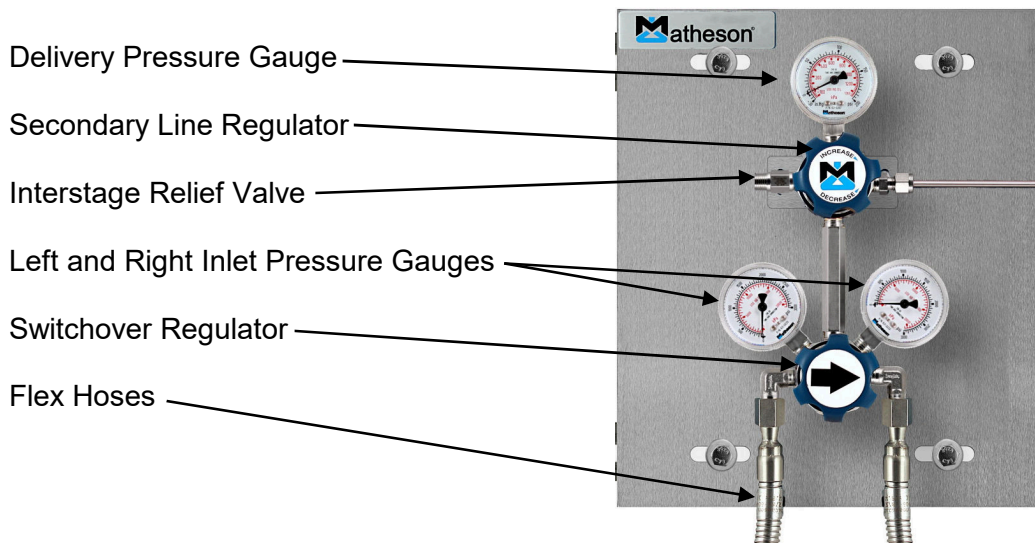

## 2.0 PURIFIER PANEL DESCRIPTION

The purifier panel was designed to be used in conjunction with the MATHESON SwitchPro™ switchover panel system. The purifier panel can also be used as a standalone panel in a line or at point of use.

The standard panel consists of one Nanochem® moisture/oxygen purifier\*. The purifier is mounted along with a digital indicator, allowing the user to observe when the purifying media is consumed. This eliminates the guess work of when to change the cartridges.

The inlet to the panel is a 1/4" compression fitting, attached to an all stainless steel flex hose. This allows for some flexibility for the inlet location.

The purifier is connected with face seal inlet and outlet fittings.

The outlet of the panel is a 1/4-turn stainless steel diaphragm valve, with a 1/4" compression fitting outlet connection.

All components are mounted to a stainless steel mounting plate with slots for wall mounting. The plate is the same size as the plate on the SwitchPro™ switchover panel.

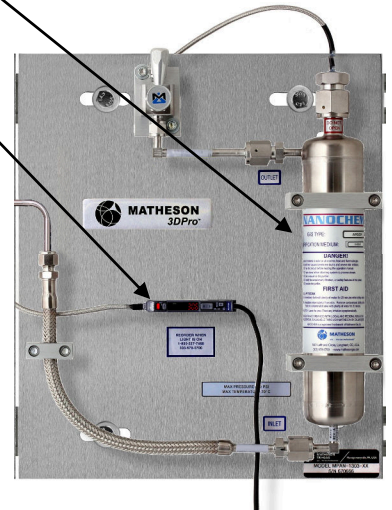

**\*The Nanochem® purifier must be purchased separately from the purifier panel, and will be shipped separately. The Nanochem® must be installed by the user before use.**



### 3.0 SWITCHOVER / PURIFIER PANEL INSTALLATION

**BEFORE ATTACHMENT OF THE SWITCHOVER SYSTEM TO THE CYLINDER, READ CAREFULLY THE "USER RESPONSIBILITY" AND "SAFETY PRECAUTIONS" SECTIONS OF THIS MANUAL**

- 3.1 Unpack the switchover / purifier panel and carefully check for damage, which might have occurred during transportation. If there is any evidence of damage, a claim must be filed with the shipper. If there is no damage, discard the wrapping.
- 3.2 If the purifier is being used with an existing switchover panel, attach both panels to the unistrut channel; there should be 1/8"-3/16" space between the panels.
- 3.3 Connect the switchover outlet to the inlet of the purifier panel with a piece of rigid tubing. Chose the material of the tubing such that the fittings are of the same or harder material than the tubing. Do not use Teflon tape or other sealant in making a compression fitting connection. If the switchover, purifier, and mounting kit were purchased together, this tubing is supplied with the system. If not, a tube bender is required to properly bend the tubing to avoid kinks. The tubing must be aligned properly in the fittings to avoid leaks.
- 3.4 Without cracking (opening) any of the seals of the switchover or purifier panel system, hang the assembly at a height that will allow the pigtails to be connected easily to the cylinders/containers. The ability to read the gauges of the system and adjust the pressures should also be considered before mounting.
- 3.5 The pigtails (typically flexible hoses) should be attached to the system, if not already attached, with open ended wrenches. Rigid pigtails should NEVER be bent or repositioned more than a few inches from its original shape. Excessive bending will cause unnecessary stresses in the metal resulting in failure of the rigid pigtail.
- 3.6 Do not connect the process line at this time. The process line can be connected after the assembly is purged.

<p><b>WARNING: BRASS COMPRESSION FITTINGS WILL NOT WORK PROPERLY WITH STAINLESS STEEL TUBING.</b></p>
---

## 4.0 Nanochem® 3DPro™ Installation & Conditioning

**Please read these instructions, carefully.** If you have any questions, please contact your local NANOCEM sales agent or MATHESON Customer Service at (800) 416-2505 or by email at [info@mathesongas.com](mailto:info@mathesongas.com), prior to installation of the purifier.

### Installation Procedure:

- 4.1 Purge all tubing, fittings, and components in the installation zone with argon.
- 4.2 Start purge flow rate of 0.5-1.0 slpm to the installation zone by opening an upstream valve.

**IMPORTANT!** Maintain purge gas flow until the installation and assembly are complete.

### **For new installations skip steps 4.3, 4.5 and 4.6.**

- 4.3 Unscrew fittings upstream and downstream of existing purifier.
- 4.4 Remove screws from purifier clamps.
- 4.5 Remove (unclip) endpoint display from base.
- 4.6 Remove purifier, endpoint display and gaskets.
- 4.7 Inspect sealing surface of gas line fittings. If damage exists, replace fittings.
- 4.8 Remove new purifier and supplied gaskets from packaging.
- 4.9 With purge gas flowing from the inlet line, remove protective cap from purifier inlet and protective plug from outlet and immediately install purifier finger tight with gasket, on inlet gas line. Allow connection to purge for 10 seconds, then tighten VCR connection per instructions below using a 5/8" open-end wrench and a 3/4" open-end wrench. Store protective cap and plug for future use.
- 4.10 Open isolation valve downstream of installation zone. Ensure gas flow path in the outlet gas line is open to vent.
- 4.11 Install outlet connection with gasket, and tighten VCR connection per instructions below using 5/8" open-end wrench and a 3/4" open-end wrench.
- 4.12 Continue flow of inert gas at 0.5-1.0 slpm for an additional 5-10 minutes.
- 4.13 Install purifier clamps and tighten screws.
- 4.14 Attach (snap on) endpoint display to base.
- 4.15 Leak test all connections.
- 4.16 After performing the installation procedure (above), the purifier is ready for conditioning.

**CAUTION!** Damage to sealing surface may result if the face seal connector is over-tightened or installed without a gasket. New purifier assembly gaskets must be installed for each connection made.

**WARNING!** Reaction of the purifier contents (purification media) with air or water evolves:

- Heat and flammable gas (for N<sub>2</sub>, Ar, He, Ne, Kr, Xe, H<sub>2</sub>)

**DO NOT puncture canister.** Modification of the purifier assembly could result in contact with chemicals that may cause severe burns to the eyes and irritation of the skin.

Hazardous gas should never be introduced into this equipment or associated piping until a field leak test demonstrates it is suitable for service. MATHESON assumes no responsibility for purifier assembly seal leakage or damage resulting from its operation. The user is ultimately responsible for equipment integrity and to comply with any applicable safety procedures.

### Conditioning Procedure:

Conditioning procedures enable NANOCHEM® purification media to either generate or inactivate certain functional groups that are chemically bonded to the media. Any stray contaminants introduced during the installation procedure are also removed during the conditioning process.

4.17 Follow purifier conditioning procedures given in Table below. Conditioning is done either with the process gas or a diluted blend, as noted.

4.18 Upon completion of the conditioning procedures, purge all connecting lines and equipment. The purifier is now ready for service.

MEDIA	PROCESS GAS	CONDITIONING PARAMETERS		
		Conditioning Gas Conc.	Flow Rate	Time
3DPro	N <sub>2</sub> , He, Ar, Ne, Kr, Xe, H <sub>2</sub>	100%	10 slpm	30 min

### NOTES:

1. Once the purifier is conditioned with a process gas, it must be left under pressure of that process gas. If the process gas is subsequently purged with an inert gas, a second conditioning may be required prior to re-use with the same process gas.
2. Conditioning may also be required if the process gas blend is replaced with a gas blend of different concentration; e.g. the process gas is changed from a 1% H<sub>2</sub>/99% Ar blend to a 5% H<sub>2</sub>/95% Ar blend.
3. A purifier conditioned for a particular process gas must be used for that process gas, only. The purification media is gas specific. Without prior authorization from MATHESON, a purifier purchased for one gas must not be used for any other gas.

### Purifier Operation:

Flow process gas through purifier at a flow rate not to exceed the maximum rated flow.

**CAUTION! If at any time, the purifier feels warm / hot to the touch, shut off process gas flow & purge purifier.** Contact MATHESON as soon as possible. Causes could be a major leak upstream of the purifier, excessively high impurity concentration, wrong process gas, or inadequate conditioning.

SDS for specific NANOCHEM purification media can be obtained by calling MATHESON Customer Service or at <https://www.chemadvisor.com/matheson/>

### Purifier Removal & Disposal:

- 4.19 Replace the purifier after its predicted lifetime.
- 4.20 Purge the purifier of hazardous gases prior to disconnection. Purge as per directions in the NANOCHEM *Media Usage Statement*.
- 4.21 Disconnect the purifier using the same procedure as described for installation. Install protective cap/plug on purifier inlet and outlet connections.

MATHESON currently utilizes Veolia Environmental Services located in Henderson, CO, USA to handle their customer's purifier disposal requirements. The user has the option of following their own protocols for the disposal of hazardous materials, including identifying and using other qualified vendors. If the user elects to use Veolia, MATHESON Customer Service can assist in the packaging, labeling, and shipment of the purifier(s). The user must fill out a NANOCHEM Media Usage Statement and send it to MATHESON. Upon approval, NANOCHEM Purification Systems will issue an RMA Number. The user must tag the spent purifier with the provided RMA Number; the NANOCHEM Media Usage Statement must accompany the purifier.

**NOTE:** Disposal of the purifier must be done in strict accordance with local, county, state / province, federal / central government, and international regulations and rules of the specific country where the purifier is used. If the user contracts with a hazardous material or hazardous waste disposal agency to dispose of the Purifier as a *Lab Pack*, the disposal agency may take care of the necessary packaging, paperwork, and transportation of the purifier to the disposal site.

NANOCHEM is a registered trademark of MATHESON Tri-Gas, Inc., Parsippany, NJ, USA  
 3DPro is a trademark of MATHESON Tri-Gas, Inc. Parsippany, NJ, USA  
 VCR is a registered trademark of Crawford Fittings, Solon, OH, USA

**VCR Fitting Installation Instructions**

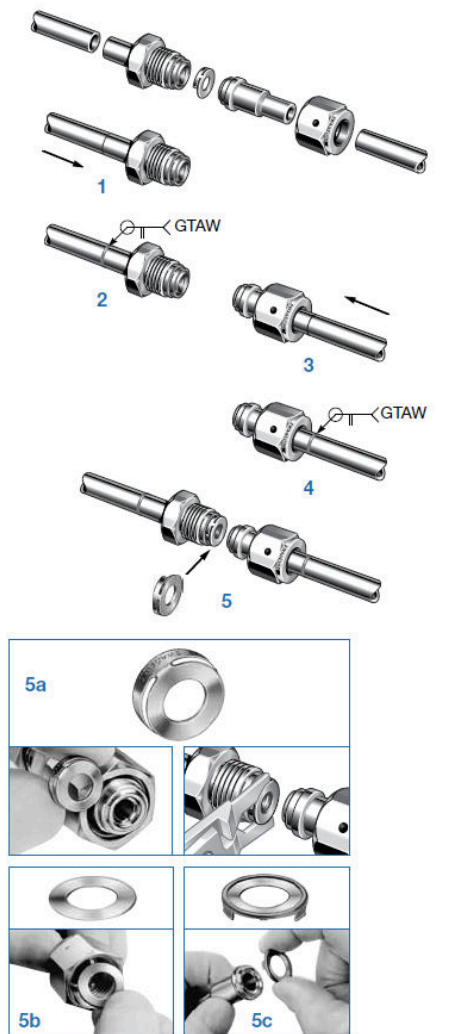

**VCR Fitting Installation Instructions**

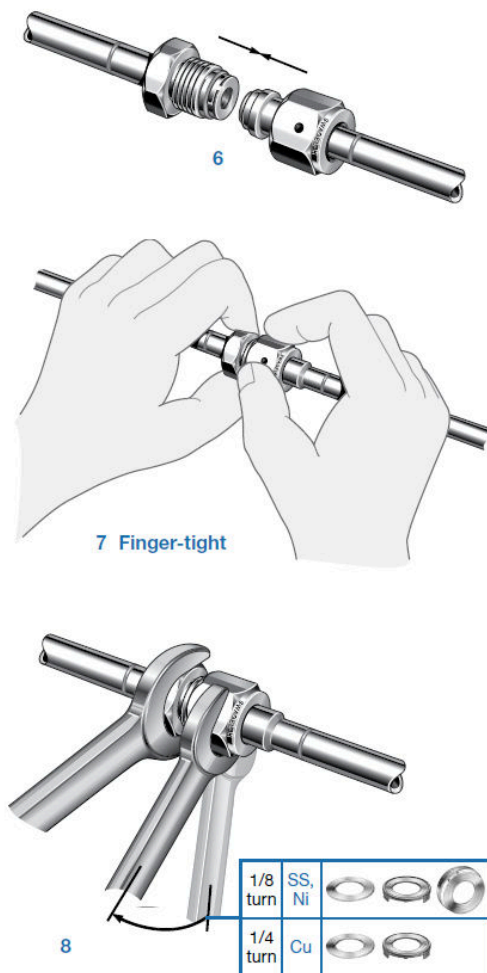

## 5.0 PROCESS CYLINDER INSTALLATION INSTRUCTIONS

- 5.1 Before removing the cylinder cap, move the cylinder of process gas to the panel.
  - 5.1.1 Secure the cylinder as to prevent accidental toppling.
  - 5.1.2 Remove the cylinder cap.
  - 5.1.3 Make certain that the cylinder valve is tightly closed.
  - 5.1.4 Remove the cylinder plug, if present. If there is any sign of gas leaking through the closed cylinder valve, replace the plug and contact THE GAS SUPPLIER IMMEDIATELY to arrange for disposal.
  - 5.1.5 Inspect the cylinder valve for contamination or abuse.
- 5.2 The user should then put on appropriate safety apparel such as, but not limited to, safety glasses and gloves.
- 5.3 Close the line regulator of the switchover system (if provided) by rotating the adjusting knob in a counterclockwise direction until no more resistance is felt. As the knob is turned, the movement of the assembly should be easier.
- 5.4 Close the High Pressure Isolation (HPI) valves (if supplied) at the inlet of the switchover system.
- 5.5 Following the procedures outlined below, make the connection of the pigtail to the cylinder valve. Always use an open ended or adjustable wrench. Always use a backup wrench on CGA connections
  - 5.5.1 **DO NOT FORCE.** The connection should be made easily. If it cannot be made easily, most likely the user has the wrong panel for the gas service.
  - 5.5.2 **LEFT HAND THREADS** are used on some CGA connections. Notches in the middle of the hex nut usually identify left hand threads.
  - 5.5.3 **GASKETS** are used in conjunction with some CGA connections. If the connection requires a gasket, one has been supplied with the panel. Inspect the gasket for signs of contamination and abuse. Do not over-tighten a connection with a gasket, as this will force the gasket to extrude into the gas stream.
  - 5.5.4 **NEVER USE LUBRICANTS OF ANY TYPE** on the CGA connection or cylinder valve to aid in connection.
  - 5.5.5 **NEVER USE TEFLON TAPE** to aid in the sealing of the CGA connection to the cylinder valve.

## 6.0 OPERATING INSTRUCTIONS - SWITCHOVER

**WARNING: THE USER SHOULD PUT ON APPROPRIATE SAFETY APPAREL SUCH AS, BUT NOT LIMITED TO, SAFETY GLASSES AND GLOVES.**

- 6.1 The line regulator control knob should be closed as described in "INSTALLATION" sections above. All valves should also be in the closed position as described in the "INSTALLATION" sections above.
- 6.2 Choose one supply side of the switchover system to be the Primary supply source and the other side to be the Reserve. If the right side cylinder(s) (facing the front of the SwitchPro™ Automatic Switchover System) is chosen as primary then rotate the switchover regulator knob fully clockwise until it hits the stop. The large arrow on the front of the knob should be pointing towards the right side cylinder. If the left side is chosen to be the primary side, then rotate the switchover regulator knob fully counterclockwise until the knob stops and the arrow points to the left side cylinder.
- 6.3 The user should then be positioned with the cylinder between themselves and the switchover system. **DO NOT REST HANDS ON OR APPLY FORCE TO THE PIGTAIL DURING THE FOLLOWING CHARGING OPERATIONS.**
- 6.4 To avoid damage to the switchover system's internal parts, open the cylinder valve(s) SLOWLY on the Primary side of the switchover system. If there is an inlet shutoff valve on the switchover system, open it slowly. Observe the high pressure gauge, on the switchover system, for a rise in pressure to full cylinder pressure.
- 6.5 Observe all high pressure connections in the pressurized system for leaks.
  - 6.5.1 An approved soap solution, if compatible with materials and applications in use, can be used to check connections for leaks.
  - 6.5.2 An approved leak detecting device can be used to check for leaks. Consult the manufacturer's instructions for applications and hazards associated with the gas to be used in the system.
  - 6.5.3 If neither method above can be utilized, re-close the cylinder valve for a minimum of five minutes and observe the high pressure gauge for a drop in pressure.
  - 6.5.4 If a leak is indicated, by any of the methods listed above, recheck the CGA connection to the cylinder and all other high pressure connections.
  - 6.5.5 If all of the connections indicate no leak and the regulator and outlet are still closed, and the pressure continues to fall on the inlet gauge, reduce the pressure in the system as outlined in the "SHUTDOWN PROCEDURES". Return the switchover system for replacement or repair (if new) or repair (if out of warranty) by following the procedure in the "WARRANTY REPAIR" section.
- 6.6 If the system has been leak checked on one side and is found to be acceptable, repeat the procedure for the Reserve side of the switchover system.

- 6.7 If both sides of the system have been leak checked on the high pressure side and found to be acceptable, open the cylinder valves completely in order to form a good seal within the cylinder valve. Keep the hand wheel or wrench (if required for this particular cylinder valve type) available at all times to allow for prompt shut-off in emergency situations.
- 6.8 Most models of the SwitchPro™ Automatic Switchover System are equipped with a secondary line regulator. For models so equipped with a secondary line regulator, follow the instructions in Section 6.8.1 below. Some models of this product are not equipped with a secondary line regulator. For those units use the procedure outlined in Section 6.8.2. To determine if the product delivered is one type or the other, refer to the original packing list and any sales or marketing literature available.
  - 6.8.1 MODELS WITH A SECONDARY LINE REGULATOR. Slowly turn the regulator knob clockwise to increase the pressure and counterclockwise to decrease the pressure, while observing the pressure gauge on the line regulator. If the delivery line is dead-ended or closed the delivery pressure cannot be relieved by turning the knob counterclockwise and a flowing condition must be established to reduce the delivery pressure. All final delivery pressure adjustments should be made with the final system flow rate established.
  - 6.8.2 MODELS WITHOUT SECONDARY LINE REGULATION. The delivery pressure on these systems is preset at the factory. The delivery pressure will vary between 180 and 220 psig depending on the position of the switchover regulator knob. If the knob position is full clockwise, with the arrow pointing down and to the right, the outlet pressure will be approximately 200 to 220 psig. If the knob position is full counterclockwise, with the arrow pointing down and to the left, the outlet pressure will be approximately 180 to 200 psig.
- 6.9 The system is now operating. Observe all low pressure connections in the pressurized system for leaks.
  - 6.9.1 Check all connections for leaks with an approved soap solution, if compatible with materials and applications in use.
  - 6.9.2 An approved leak detecting device can be used to check for leaks. Consult the manufacturer's instructions for applications and hazards associated with the gas to be used in the system.
  - 6.9.3 If neither of the above methods can be utilized and the system has a line regulator, close off the system as close to the switchover system as possible, including the line regulator, and observe the pressure gauges for a drop in pressure.
- 6.10 If the system is to put into service immediately, make sure that the switchover is properly connected to the line and has been fully leak tested. Then open all cylinder valves and isolation valves and adjust the line regulator to the desired working pressure.
- 6.11 If the system will not be used immediately, close all cylinder valves and vent the system through the outlet of the system in a suitable manner consistent with safe handling procedures.

## 7.0 CYLINDER CHANGEOUT

After the switchover has occurred, determined by the depletion of original cylinder pressure to the switchover pressure (typically 180-200 psig) as indicated on the respective high pressure gauge, perform the following steps for cylinder(s) replacement.

- 7.1 Turn the switchover regulator knob 180 degrees away from the cylinder that has been depleted. If the right side was the primary supply and is now depleted turn the switchover regulator knob in the counterclockwise direction until the arrow on the knob points at the left side cylinder and hits the stop. If the left side was the primary supply and is now depleted turn the switchover regulator knob in the clockwise direction until the arrow on the knob points at the right side cylinder and hits the stop.
- 7.2 Close the depleted side High Pressure Isolation (HPI) valve (if supplied) by turning the knob fully clockwise.
- 7.3 Close the process gas cylinder valve(s) on the depleted side of the switchover system.
  - 7.3.1 Open the High Pressure Vent (HPV) valve (if supplied) on the depleted side of the switchover system for 10 seconds, then close. Verify cylinder pressure is zero (0) psig.
  - 7.3.2 Wait 60 seconds minimum and again verify cylinder pressure indication is zero (0) psig. If pressure has increased, then the cylinder valve is leaking past the seat. If the cylinder valve is leaking, open the cylinder valve and close again tightly; then return to step 7.3.1. Do not proceed if the cylinder valve continues to leak; contact your GAS SUPPLIER for assistance.
  - 7.3.3 Open the HPV valve for 10 seconds then close. Verify cylinder pressure indication is zero (0) psig.
- 7.4 Disassemble the pigtail(s) from the cylinder(s) by slowly loosening the cylinder connection. Listen for continuous gas seepage. If leaking is evident, re-tighten the cylinder connection immediately and check the cylinder valve for proper closure. If the cylinder valve is in the closed position, and the switchover system has been drained of all gases, contact your GAS SUPPLIER immediately and notify him of the situation.
- 7.5 Replace plug into the cylinder valve outlet (where applicable). Replace the cap on the cylinder over the valve. Remove the cylinder from the work place and put the cylinder into a safe storage area.
- 7.6 Inspect the cylinder connection sealing surface on the pigtail for dirt, scratches, dents, pits, or corrosion. Clean or replace parts if needed.
- 7.7 Move the cylinder of gas to the work site before removing the cap. Fasten the safety strap and/or chain. Remove the cylinder cap. Make certain that the cylinder valve is tightly closed then remove the cylinder plug, if present.
- 7.8 Inspect the cylinder valve sealing surface for dirt, scratches, dents, pits, or corrosion. Clean as indicated. Do not attempt to connect a cylinder that is any way defective.



- 7.9 Following the procedures outlined below, make the connection of the pigtail to the cylinder valve. Always use an open ended or adjustable wrench. Always use a backup wrench on CGA connections
- 7.9.1 **DO NOT FORCE.** The connection should be made easily. If it cannot be made easily, most likely the user has the wrong panel for the gas service.
  - 7.9.2 **LEFT HAND THREADS** are used on some CGA connections. Notches in the middle of the hex nut usually identify left hand threads.
  - 7.9.3 **GASKETS** are used in conjunction with some CGA connections. If the connection requires a gasket, one has been supplied with the panel. Inspect the gasket for signs of contamination and abuse. Do not over-tighten a connection with a gasket, as this will force the gasket to extrude into the gas stream.
  - 7.9.4 **NEVER USE LUBRICANTS OF ANY TYPE** on the CGA connection or cylinder valve to aid in connection.
  - 7.9.5 **NEVER USE TEFLON TAPE** to aid in the sealing of the CGA connection to the cylinder valve.
- 7.10 If the switchover system is supplied with a High Pressure Vent (HPV) valve then:
- 7.10.1 Close the HPI valve (if supplied).
  - 7.10.1 Close the HPV valve (if supplied).
  - 7.10.2 SLOWLY open the process gas cylinder valve(s) of the newly attached cylinder(s).
  - 7.10.3 Close the process cylinder valve(s).
  - 7.10.4 Open the HPV valve to allow all of the gas in the system to be evacuated through the vent line.
  - 7.10.5 Close the HPV valve as soon as the pressure is gone.
  - 7.10.6 Repeat steps 7.10.1 to 7.10.5 a minimum of five and a maximum of 25 times dependant upon the user's experience with purging techniques and recommendations.
- 7.11 SLOWLY open the process gas cylinder valve(s) of the newly attached cylinder(s).
- 7.12 Open the High Pressure Isolation (HPI) valve (if supplied)
- 7.13 Wait five seconds minimum or until cylinder pressure indication stabilizes. Verify full cylinder pressure indication then close the cylinder valve(s).
- 7.14 Wait for five minutes minimum and monitor cylinder pressure display. A drop in pressure indicates a potential leak. Ensure that the HPV (if supplied) is full closed. Leak check the inlet section of the switchover system. Repair any leaks before proceeding.
- 7.15 The process cylinders are now in service.

## 8.0 SHUTDOWN PROCEDURES

### 8.1 Temporary Shutdown

Close the High Pressure (HPI) valves (if supplied). If HPI valves are not supplied then close the process cylinder valves

### 8.2 Extended Shutdown

8.2.1 Close the process gas cylinder valves.

8.2.2 Shut down any additional gas supplies that may be supplying gas to the system.

8.2.3 Open the regulators and the isolation valves to drain the contents of the switchover system through the line using the gas supplied by the unit. All gauges should descend to zero.

8.2.4 When using a toxic or other hazardous gas, run an inert gas through the switchover system and the line using the switchover system as a means to purge the toxic or hazardous gas out of the system before breaking any of the system connections.

8.2.5 After venting (and purging when necessary), close all of the regulators and the valves of the switchover system.

8.2.6 Isolate the switchover system from line system and downstream equipment.

8.2.7 Disassemble the pigtails from the cylinders by slowly loosening the cylinder connection. Listen for continuous gas seepage. If leaking is evident, re-tighten the cylinder connection immediately and check the cylinder valve for proper closure. If the cylinder valve is in the closed position, and the switchover system has been drained of all gases, contact the GAS SUPPLIER immediately and notify him of the situation.

8.2.8 Replace plug into cylinder valve outlet (where applicable). Replace the cap on the cylinder over the valve. Remove the cylinder from the work place and put the cylinder into a safe storage area.

8.2.9 Cap or plug exposed ports to prevent contamination.

## 9.0 TROUBLESHOOTING

- 9.1 Gauges should always read zero when all gas is drained from the switchover system. If they do not read zero they may have to be replaced
- 9.2 No gas should be coming out of the outlet when the switchover system or valves are in the closed position. If there is gas flow, this is an indication of regulator or valve seat failure or imminent seat failure.
- 9.3 The delivery pressure of the regulators within the switchover system should not rise with the cylinder valves open, the regulators set at a given delivery pressure and the outlet valves closed for five to ten minutes. If there is a pressure rise, this is an indication of regulator seat failure or imminent seat failure.
- 9.4 Gas leakage should never occur from the bonnet (end of the regulator with adjusting knob or handle). If there is gas leakage, it is possible that the diaphragm or diaphragm seal is deficient.
- 9.5 Connections on the switchover system should be periodically checked for leaks. Presence of leaking seals is indicative of deficient switchover system performance.
- 9.6 There should be no excessive periodic drop in flow from the outlet of the switchover when in service. If this occurs, there is most likely a blockage or occlusion in the flow path.
- 9.7 To ensure long life of the switchover system, on a schedule consistent with user experience, regulators within the switchover system should be reconditioned for full service.

IF ANY OF THE ABOVE NOTED DEFICIENCIES ARE OBSERVED BY THE USER, THE UNIT SHOULD IMMEDIATELY BE REMOVED FROM SERVICE AND ARRANGEMENTS MADE FOR REPAIR OR REPLACEMENT OF THE DEFICIENT PRODUCT.

## APPENDIX - FITTINGS

1. **COMPRESSION TUBE FITTINGS** are supplied as connections on most MATHESON SwitchPro™ Automatic Switchover Systems. These connections are for use with 1/4" OD rigid metal tubing. Dependent upon the application, the tubing material will either be Brass, Copper, Stainless Steel or Monel. Connect the rigid tubing to the outlet of the Panel and then to the equipment utilizing the manufacturer's instructions for making compression tube connections. **WARNING: MOST APPROVED AND RELIABLE COMPRESSION TUBE CONNECTIONS UTILIZE FERRULES FOR COMPRESSION OF THE FITTING ONTO THE TUBE. THESE FERRULES ARE TO BE USED FOR ONE (1) CONNECTION ONLY AND MUST NOT BE USED ON ANOTHER PIECE OF TUBING. NEVER USE TEFLON TAPE IN MAKING A COMPRESSION TUBE CONNECTION.**
2. VCR or FACE SEAL CONNECTIONS are supplied as inlet and/or outlet connections on some MATHESON Panels. Standard connections provided are either 1/4" or 1/2" male or female dependent upon customer order. Connections are to be made only to compatible connections within the User's system. VCR or VCR-Type connections utilize an expendable gasket for sealing which may or may not be supplied. **WARNING: VCR AND FACE SEAL CONNECTIONS USE EXPENDABLE GASKETS. THESE GASKETS ARE TO BE UTILIZED ONLY FOR ONE ATTEMPT AT SEALING AND SHOULD NEVER BE REUSED. MAKE CERTAIN THAT THE GASKETS TO BE EMPLOYED ARE COMPATIBLE WITH THE GAS SERVICE INTENDED.**
3. CGA connections are supplied on pigtails for the connection of the process gas cylinder to the panel.
  - a. **DO NOT FORCE.** The connection should be made easily. If it cannot be made easily, most likely the user has the wrong panel for the gas service.
  - b. **LEFT HAND THREADS** are used on some CGA connections. Notches in the middle of the hex nut usually identify left hand threads.
  - c. **GASKETS** are used in conjunction with some CGA connections. If the connection requires a gasket, one has been supplied with the panel. Inspect the gasket for signs of contamination and abuse. Do not over-tighten a connection with a gasket, as this will force the gasket to extrude into the gas stream.
  - d. **NEVER USE LUBRICANTS OF ANY TYPE** on the CGA connection or cylinder valve to aid in connection.
  - e. **NEVER USE TEFLON TAPE** to aid in the sealing of the CGA connection to the cylinder valve.









**MATHESON**

**The Gas Professionals**

166 Keystone Drive  
Montgomeryville, PA 18936  
800-828-4313  
www.mathesongas.com  
INT-0349-XX Rev B

Copyright 2021 Matheson Tri-Gas, Inc. All Rights Reserved.

All contents of this document are subject to change without notice and do not represent a commitment on the part of Matheson Tri-Gas, Inc. Every effort is made to ensure the accuracy of this information. However, due to differences in actual and ongoing operational processes and product improvements and revisions, Matheson Tri-Gas, Inc. cannot guarantee the accuracy of this material, nor can it accept responsibility for errors or omissions. This document is intended to serve as a general orientation and cannot be relied upon for a specific operation. No warranties of any nature are extended by the information contained in these copyrighted materials. All names, products, and services mentioned herein are the trademarks or registered trademarks of their respective organizations and are the sole property of their respective owners.

MATHESON and the MATHESON logo are registered trademarks of Matheson Tri-Gas, Inc.

TERMS AND CONDITIONS OF SALE

<https://shop.mathesongas.com/terms-and-conditions>